



A025DN01 VB Product Spec	Version	0.3
	Page	1/60

CUSTOMER APPROVAL SHEET

Company Name	
MODEL	
CUSTOMER APPROVED	Title : Name :

- APPROVAL FOR SPECIFICATIONS ONLY (Spec. Ver.____)
- APPROVAL FOR SPECIFICATIONS AND ES SAMPLE (Spec. Ver.____)
- APPROVAL FOR SPECIFICATIONS AND CS SAMPLE (Spec. Ver.____)
- CUSTOMER REMARK :

AUO PM :

P/N : _____

Comment :

1 Li-Hsin Rd. 2. Science-Based Industrial Park
Hsinchu 300, Taiwan, R.O.C.
Tel: +886-3-500-8899
Fax: +886-3-577-2730



A025DN01 VB Product Spec	Version	0.3
	Page	2/60

Doc. version:	0.3
Total pages:	60
Date:	2009/09/30

Product Specification

2.5" COLOR TFT-LCD MODULE

MODEL NAME: A025DN01 VB

- < ◆ > Preliminary Specification
< > Final Specification

Model Name : **A025DN01 VB**

Planned Lifetime: From 2009/Nov. To 2010/Nov

Phase-out Control: From 20010/July. To 2010/Nov

EOL Schedule: 20010/July

Note: The content of this specification is subject to change without prior notice.

© 2009 AU Optronics
All Rights Reserved,
Do Not Copy.



A025DN01 VB Product Spec	Version	0.3
	Page	4/60

Contents

A. Physical specifications	6
B. Electrical specifications	7
1. Pin assignment	7
2. Absolute maximum ratings	10
3. Electrical characteristics	11
3.1 Recommended operating conditions (GND=AGND=0V)	11
3.2 Electrical characteristics (GND=AGND=0V)	11
3.3 Recommended Capacitance Values of External Capacitor	12
3.4 LED driving conditions	12
4. Input timing AC characteristic	13
5. Input timing format	14
5.1 UPS051 timing conditions (Refer to Fig.1 Fig.2 Fig.3)	14
5.2 UPS052 timing	17
5.2.1 UPS052 (320 mode/NTSC/24.535MHz) timing specifications. (refer to Fig.4 Fig.5)	17
5.2.2 UPS052 (320 mode/PAL/24.375MHz) timing specifications (refer to Fig.4 Fig.5)	17
5.2.3 UPS052 (360 mode/NTSC/27MHz) timing specifications (refer to Fig.4 Fig.5)	18
5.2.4 UPS052 (360 mode/PAL/27MHz) timing specifications (refer to Fig.4 Fig.5)	18
5.3 CCIR656 Timing	21
5.3.1 CCIR656 decoding	21
5.3.2 CCIR656 NTSC	22
5.3.3 CCIR656 PAL	22
5.4 YUV 720 and YUV 640 timing	23
5.4.1 YUV 720 mode/NTSC timing specifications (refer to Fig.7 Fig.9)	23
5.4.2 YUV 720 mode/PAL timing specifications (refer to Fig.7 Fig.9)	23
5.4.3 YUV 640 mode/NTSC timing specifications (refer to Fig.8 Fig.9)	24
5.4.4 YUV 640 mode/PAL timing specifications (refer to Fig.8 Fig.9)	24
5.5 CCIR656/YUV 720/YUV 640 to RGB conversion	27
6. Serial control interface AC characteristic	28
6.1 Timing chart	28
6.2 The configuration of serial data at SDA terminal is at below	29
6.3 Register table	30
6.4 Register description	31
C. Optical specification (Note 1,Note 2, Note 3)	44
D. Reliability test items	46
E. Packing form	48
F. Outline dimension	49



A025DN01 VB Product Spec	Version	0.3
	Page	5/60

G. Application note	50
1. Application circuit.....	50
1.1 With internal LED driver circuit	50
1.2 With external LED driver circuit	51
2. Power on/off sequence.....	52
2.1 Power on (Standby Disabling).....	52
2.2 Power off (Standby Enabling)	53
3. Recommended power on/off serial command settings	54
3.1 UPS051	54
3.2 UPS052 320 mode.....	55
3.3 UPS052 360 mode.....	56
3.4 CCIR656	57
3.5 YUV 720	58
3.6 YUV 640	59
4. Power generation circuit.....	60

For Foxconn Internal Reference Only
AUO Confidential For Eric Internal Use Only / 2009/12/25



A025DN01 VB Product Spec	Version	0.3
	Page	6/60

A. Physical specifications

NO.	Item	Specification	Remark
1	Display resolution (dot)	960(W) x 240(H)	
2	Active area (mm)	49.92 x 37.44	
3	Screen size (inch)	2.457 (Diagonal)	
4	Dot pitch (um)	52 x 156	
5	Color configuration	R, G, B delta	
6	Overall dimension (mm)	59.63 x 43.7 x 2.7	Note 1
7	Weight (g)	TBD	
8	Panel surface treatment	Hard coating	

Note 1: Refer to F. Outline Dimension



A025DN01 VB Product Spec	Version	0.3
	Page	7/60

B. Electrical specifications

1. Pin assignment

Pin no	Symbol	I/O	I/O Structure	Description	Remark
1	VCOM	I	-	Panel common voltage	
2	CS	I	Type 3	Serial command enable	
3	SDA	I	Type 2	Serial command data input	
4	SCL	I	Type 1	Serial command clock input	
5	HSYNC	I	Type 1	Horizontal sync input	
6	VSYNC	I	Type 1	Vertical sync input	
7	DCLK	I	Type 1	Data clock input	
8	D7	I	Type 1	Data input; MSB	
9	D6	I	Type 1	Data input	
10	D5	I	Type 1	Data input	
11	D4	I	Type 1	Data input	
12	D3	I	Type 1	Data input	
13	D2	I	Type 1	Data input	
14	D1	I	Type 1	Data input	
15	D0	I	Type 1	Data input; LSB	
16	GND	P	-	Ground for digital circuit	
17	VDD	P	-	System power	3.0V~3.6V
18	DVDD	C	-	Power setting capacitor connect pin	
19	V1	C	-	Power setting capacitor connect pin	
20	V2	C	-	Power setting capacitor connect pin	
21	V3	C	-	Power setting capacitor connect pin	
22	V4	C	-	Power setting capacitor connect pin	
23	VDD2	C	-	Power setting capacitor connect pin	
24	V5	C	-	Power setting capacitor connect pin	
25	V6	C	-	Power setting capacitor connect pin	
26	VDD3	C	-	Power setting capacitor connect pin	
27	VDD5	C	-	Power setting capacitor connect pin	
28	V7	C	-	Power setting capacitor connect pin	
29	V8	C	-	Power setting capacitor connect pin	
30	VGH	C	-	Power setting capacitor connect pin	
31	VGL	C	-	Power setting capacitor connect pin	
32	AGND	P	-	Ground for analog circuit	

33	FRP	O	Type 4	Frame polarity output for VCOM	
34	COMDC	O	Type 5	VCOM DC voltage output pin	
35	VCAC	C	-	Power setting capacitor for VCOM AC	
36	DRV	P	-	VLED boost transistor driving signal	
37	VLED	P	Type 6	LED power anode	
38	FB	P	Type 7	LED power cathode	
39	VCOM	I	-	Panel common voltage	

I : Input, O : Output, C : Capacitor, P : Power, D : Dummy

Note: Definition of scanning direction, Refer to figure as below :

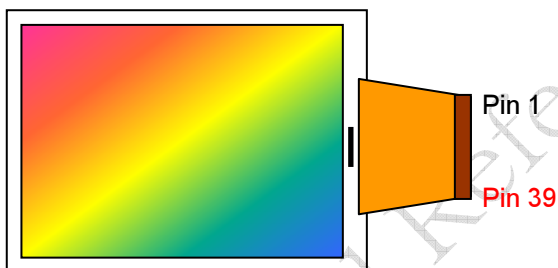

I/O Pin Structure:

Pull high/low resistor is **700kΩ**

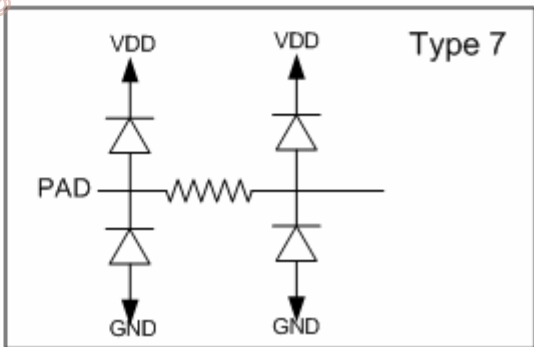
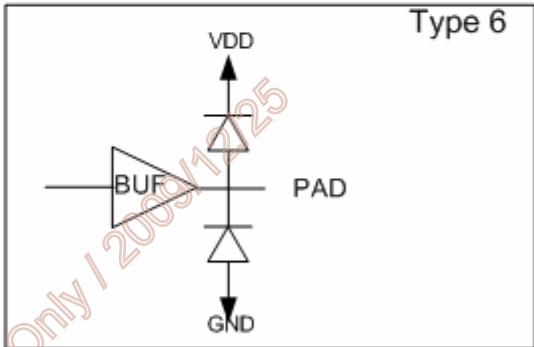
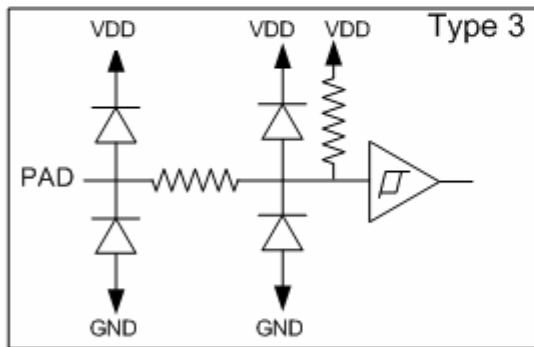
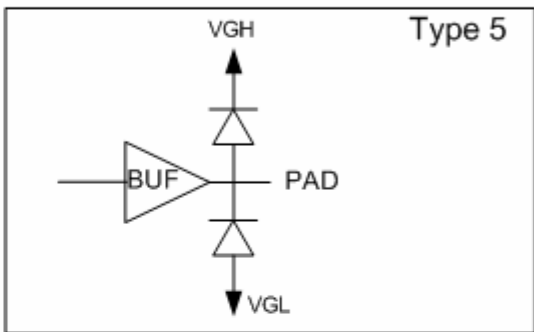
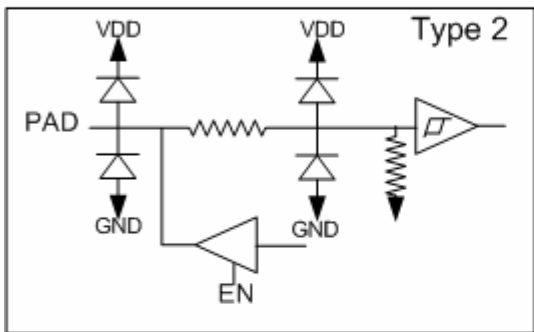
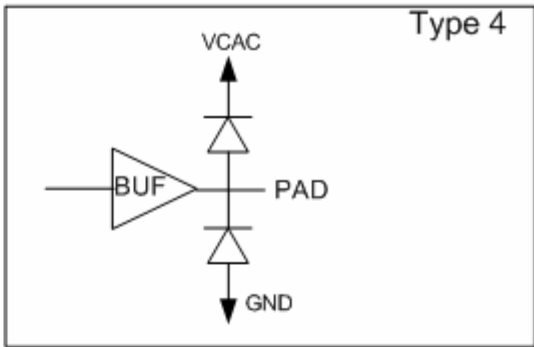
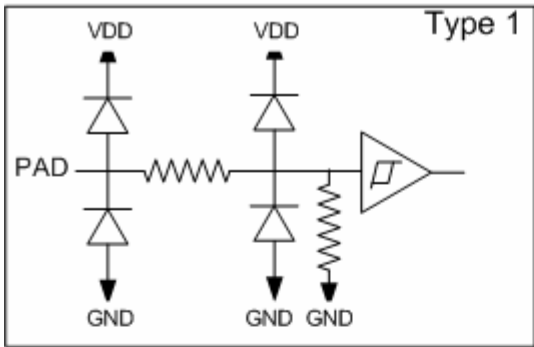



A025DN01 VB Product Spec	Version	0.3
	Page	10/60

2. Absolute maximum ratings

Item	Symbol	Condition	Min.	Max.	Unit	Remark
Supply Voltage	VDD	AGND=GND=0V	-0.3	4.5	V	
TFT-LCD Power Voltage	VGH	AGND=GND=0V	-0.3	16	V	
	VGL	AGND=GND=0V	-16	0.3	V	
Input Signal Voltage	CS,SDA,SCL,Vsync,Hsync,DCLK,D0~D7	AGND=GND=0V	-0.3	4.5	V	
VCOM AC Output Voltage	FRP	AGND=GND=0V	-0.3	8	V	
VCOM AC Power Voltage	VCAC	AGND=GND=0V	-0.3	8	V	
VCOM DC Output Voltage	COMDC	AGND=GND=0V	-0.3	8	V	
VCOM Input Voltage	VCOM	AGND=GND=0V	-0.3	8	V	
Charge Pump Voltage	VDD2	AGND=GND=0V	-0.3	8	V	
	VDD3	AGND=GND=0V	-0.3	16	V	
	VDD5	AGND=GND=0V	-0.3	20	V	
	V1	AGND=GND=0V	-0.3	8	V	
	V2	AGND=GND=0V	-0.3	8	V	
	V3	AGND=GND=0V	-0.3	8	V	
	V4	AGND=GND=0V	-0.3	8	V	
	V5	AGND=GND=0V	-0.3	16	V	
	V6	AGND=GND=0V	-0.3	16	V	
	V7	AGND=GND=0V	-0.3	16	V	
V8	AGND=GND=0V	-16	8	V		
Storage Temperature	Tstg	-	0	70	□	Ambient temperature
Operating Temperature	Topa	-	0	60	□	Ambient temperature

3. Electrical characteristics

3.1 Recommended operating conditions (GND=AGND=0V)

Item	Symbol	Min.	Typ.	Max.	Unit	Remark	
Power supply	VDD	3.0	3.3	3.6	V	Note 1	
Input Signal	H Level	V_{IH}	$0.7 * VDD$	-	VDD	V	
	L Level	V_{IL}	GND	-	$0.3 * VDD$	V	

Note 1: A build-in power on reset circuit for VDD is provided within the integrated LCD driver IC. The LCD module is in power save mode in default, and a standby releasing is required after VDD power on through serial control. Please refer to the register STB setting for detail.

3.2 Electrical characteristics (GND=AGND=0V)

Parameter	Symbol	Condition	Min.	Typ.	Max.	Unit	Remark
Input Current for V _{DD}	I _{DD}	V _{DD} =3.3V		8.2	10	mA	Note 1
	I _{DD(STANDBY)}			0.08	0.15		Note 1
DC-DC voltage	V _{GH}	V _{DD} =3.3V	14.5	15	15.5	V	Note 2
	V _{GL}	V _{DD} =3.3V	-10.5	-10	-9.5	V	Note 2
VCOM voltage	V _{CAC}	-	3.6	4.2	4.8	Vp-p	AC component, Note 3
	V _{CDC}	-	-0.3	-0.15	0	V	DC component, Note 4

Note 1: Test Condition: 8colorbar+Grayscale pattern, UPS051 mode, DCLK=27MHz, Frame rate: 60Hz, other registers are default setting.

Note 2: V_{GH} and V_{GL} are output voltages of integrated LCD driver IC.

Note 3: The brightness of LCD panel could be adjusted by the adjustment of the AC component of VCOM.

Note 4: V_{CDC} could be adjusted, so as to minimize flicker and maximum contrast on each module.



A025DN01 VB Product Spec	Version	0.3
	Page	12/60

3.3 Recommended Capacitance Values of External Capacitor

The recommended capacitance values of the external capacitor are shown below. These values should be finally determined only after performing sufficient evaluation on the module.

Pin name	Recommended value of capacitors (μ F)	Withstanding voltage (V)
VGH	4.7 to 10	25
VGL	4.7 to 10	16
VDD5	4.7 to 10	25
VDD3	4.7 to 10	16
VDD2	4.7 to 10	10
DVDD	4.7 to 10	6.3
VCAC	4.7 to 10	10
V1, V2	2.2 to 10	10
V3, V4	2.2 to 10	10
V5, V6	2.2 to 10	16
V7, V8	2.2 to 10	16

3.4 LED driving conditions

Parameter	Symbol	Min.	Typ.	Max.	Unit	Remark
LED current			25	30	mA	
LED voltage	V_L		3.2	3.5	V	1pc LED
Feedback voltage	V_{FB}	-	0.6	-	V	

Note1: If using LCD internal LED driver controller the maximum setting should be 25mA. Ta=25°C

4. Input timing AC characteristic

(VDD=3.0 ~3.6V, AGND=GND=0V, TA=25°C)

Parameter	Symbol	Min.	Typ.	Max.	Unit	Remark
CLK time	t_{DCLK}	33	-	188	ns	
DCLK width	t_{cw}	16.5	-	94	ns	$D_{cw}=50\%$
DCLK duty cycle	Tcw	40	50	60	%	
VSYNC setup time	T_{vst}	6	-	-	ns	
VSYNC hold time	T_{vhc}	6	-	-	ns	
HSYNC setup time	T_{hst}	6	-	-	ns	
HSYNC hold time	T_{hhd}	6	-	-	ns	
Data setup time	T_{dst}	6	-	-	ns	
Data hold time	T_{dhd}	6	-	-	ns	
HSYNC width	T_{hsw}	1	1	254	t_{DCLK}	
VSYNC width	T_{vsw}	1 t_{DCLK}	1 t_{DCLK}	6H		

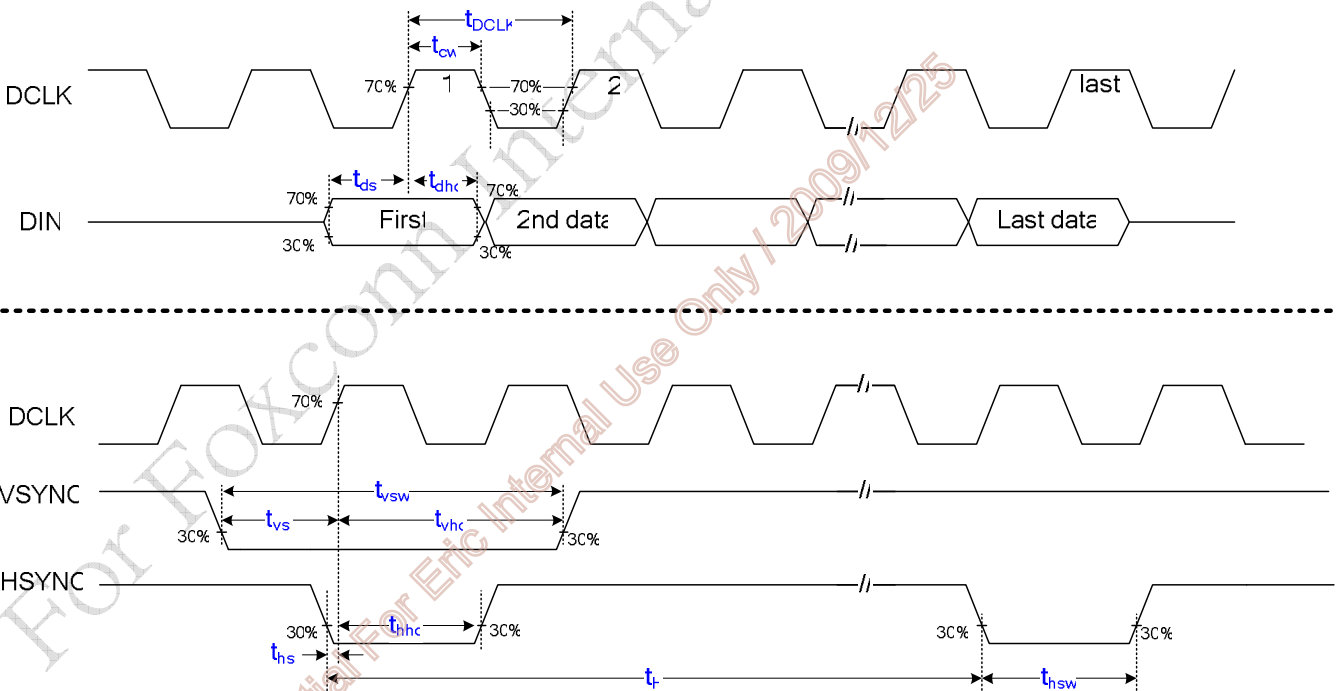

t_H means: HSYNC period

5. Input timing format

5.1 UPS051 timing conditions (Refer to Fig.1 Fig.2 Fig.3)

Parameter		Symbol	Min.	Typ.	Max.	Unit.	Remark	
DCLK Frequency		$1/t_{DCLK}$	13.5	27	27.19	MHz		
HSYNC	Period	t_H	1024	1716	1728	t_{DCLK}		
	Display period	t_{hd}	960			t_{DCLK}		
	Back porch	t_{hbp}	50	70	255	t_{DCLK}	Note 1	
	Front porch	t_{hfp}	14	686	718	t_{DCLK}		
	Pulse width	t_{hsw}	1	1	$t_{hbp} - 1$	t_{DCLK}		
VSYNC	Period	Odd	t_V	242.5	262.5	450.5	t_H	
		Even						
	Display period	Odd	t_{vd}	240			t_H	
		Even						
	Back porch	Odd	t_{vbp}	1	21	31	t_H	
		Even		1.5	21.5	31.5		
	Front porch	Odd	t_{vfp}	1.5	1.5	179.5	t_H	
		Even		1	1	179		
	Pulse width	Odd	t_{vsw}	$1 t_{DCLK}$	$1 t_{DCLK}$	$6 t_H$		
		Even						
1 frame			485	525	901	t_H		

Note 1: The t_{hbp} time is adjustable by setting register HBLK; requirement of minimum blanking time and minimum front porch time must be satisfied.

Note 2: The t_{vbp} time is adjustable by setting register VBLK. UPS051 accepts both interlace and non-interlace vertical input timing.

Fig.1 UPS051 Input Horizontal Timing Chart

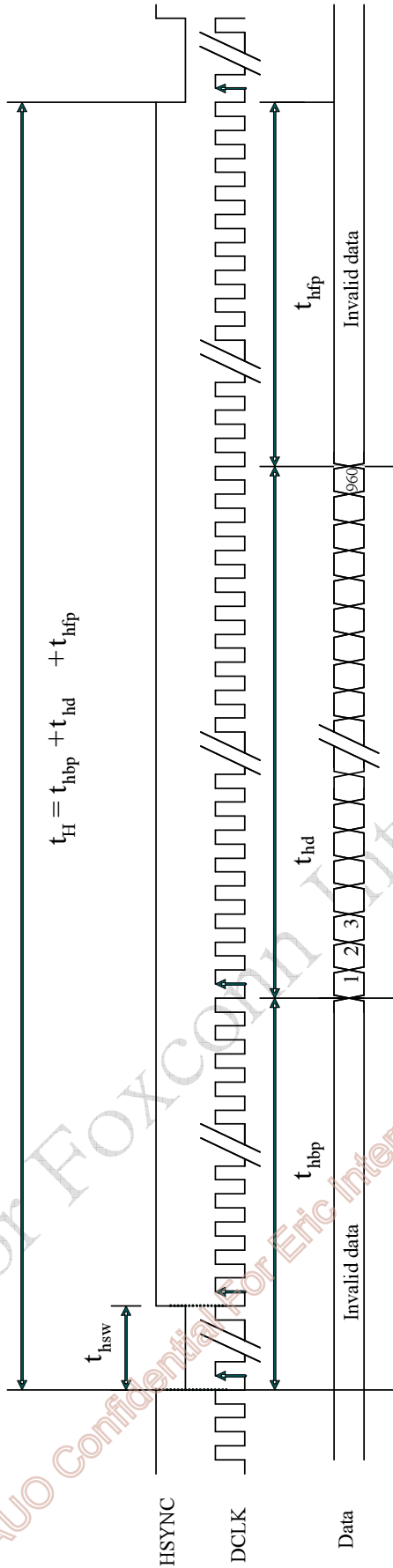
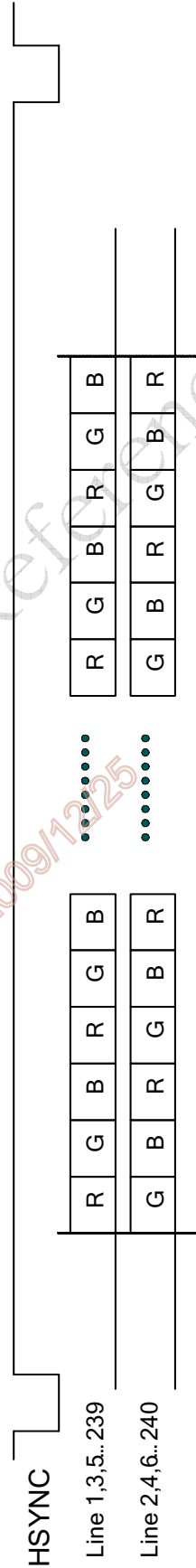
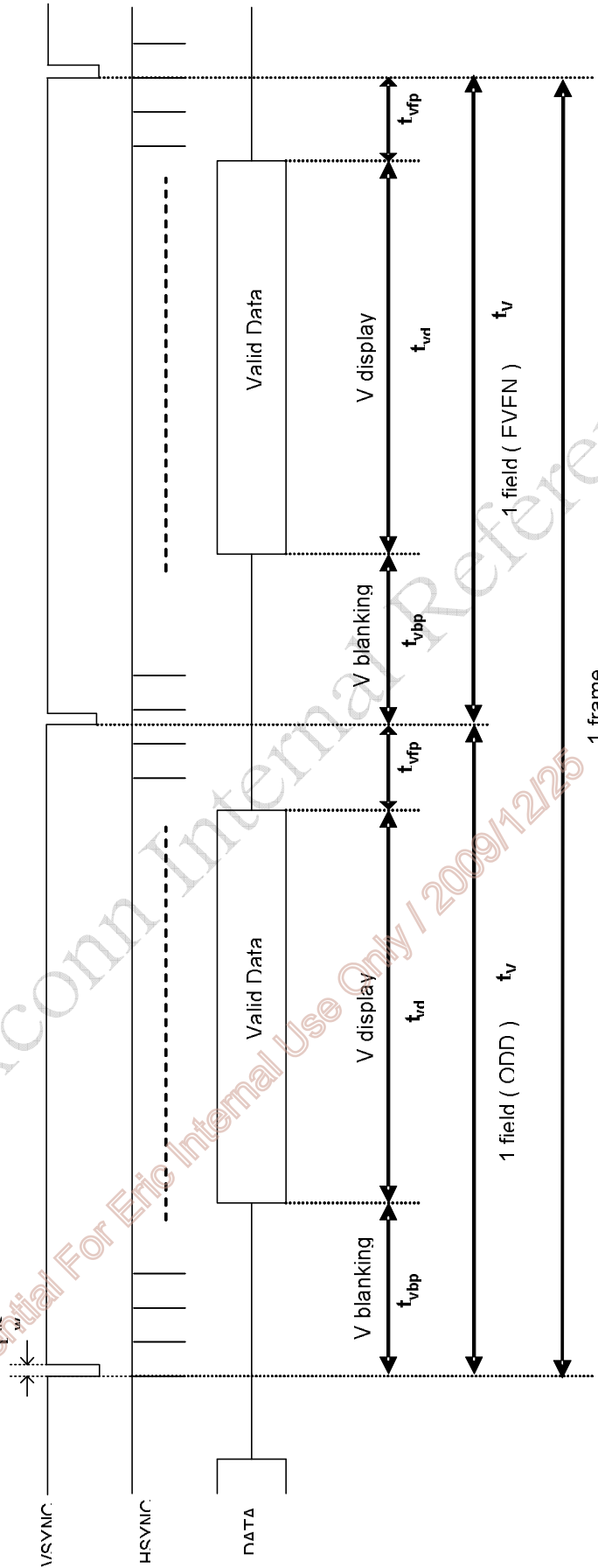

Fig.2 UPS051 Input Horizontal Data Sequence



Note: Data sequence is base on color filter arrangement.

Fig.3 UPS051 Input Vertical Timing Chart



5.2 UPS052 timing

5.2.1 UPS052 (320 mode/NTSC/24.535MHz) timing specifications. (refer to Fig.4 Fig.5)

Parameter		Symbol	Min.	Typ.	Max.	Unit.	Remark
DCLK Frequency		$1/t_{DCLK}$	20.54	24.535	30	MHz	
HSYNC	Period	t_H	1306	1560	1907	t_{DCLK}	
	Display period	t_{hdisp}	-	1280	-	t_{DCLK}	
	Back porch	t_{hbp}	2	241	255	t_{DCLK}	
	Front porch	t_{hfp}	25	39	372	t_{DCLK}	
	Pulse width	t_{hsw}	1	1	200	t_{DCLK}	
VSYNC	Period	Odd	242.5	262.5	450.5	t_H	
		Eve					
	Display period	Odd	-	240	-	t_H	
		Eve					
	Back porch	Odd	1	21	31	t_H	
		Eve	1.5	21.5	31.5		
	Front porch	Odd	1.5	1.5	179.5	t_H	
		Eve	1	1	179		
	Pulse width	Odd	1	1	200	t_{DCLK}	
		Eve					
1 frame			485	525	901	t_H	

5.2.2 UPS052 (320 mode/PAL/24.375MHz) timing specifications (refer to Fig.4 Fig.5)

Parameter		Symbol	Min.	Typ.	Max.	Unit.	Remark
DCLK Frequency		$1/t_{DCLK}$	20.4	24.375	30	MHz	
HSYNC	Period	t_H	1306	1560	1920	t_{DCLK}	
	Display period	t_{hdisp}	-	1280	-	t_{DCLK}	
	Back porch	t_{hbp}	3	241	255	t_{DCLK}	
	Front porch	t_{hfp}	24	39	385	t_{DCLK}	
	Pulse width	t_{hsw}	1	1	200	t_{DCLK}	
VSYNC	Period	Odd	292.5	312.5	450.5	t_H	
		Eve					
	Display period	Odd	-	288	-	t_H	
		Eve					
	Back porch	Odd	3	24	34	t_H	
		Eve	3.5	24.5	34.5		
	Front porch	Odd	1.5	0.5	128.5	t_H	
		Eve	1	0	128		
	Pulse width	Odd	1	1	200	t_{DCLK}	
		Eve					
1 frame			585	625	901	t_H	

5.2.3 UPS052 (360 mode/NTSC/27MHz) timing specifications (refer to Fig.4 Fig.5)

Parameter		Symbol	Min.	Typ.	Max.	Unit.	Remark	
DCLK Frequency		$1/t_{DCLK}$	23	27	30	MHz		
HSYNC	Period	t_H	1466	1716	1907	t_{DCLK}		
	Display period	t_{hdisp}	-	1440	-	t_{DCLK}		
	Back porch	t_{hbp}	2	241	255	t_{DCLK}		
	Front porch	t_{hfp}	24	35	212	t_{DCLK}		
	Pulse width	t_{hsw}	1	1	200	t_{DCLK}		
VSYNC	Period	Odd	242.5	262.5	450.5	t_H		
		Even						
	Display period	Odd	t_{vdisp}	-	240	-	t_H	
		Even						
	Back porch	Odd	t_{vbp}	1	21	31	t_H	
		Even		1.5	21.5	31.5		
	Front porch	Odd	t_{vfp}	1.5	1.5	179.5	t_H	
		Even		1	1	179		
	Pulse width	Odd	t_{vsw}	1	1	200	t_{DCLK}	
		Even						
	1 frame			485	525	901	t_H	

5.2.4 UPS052 (360 mode/PAL/27MHz) timing specifications (refer to Fig.4 Fig.5)

Parameter		Symbol	Min.	Typ.	Max.	Unit.	Remark	
DCLK Frequency		$1/t_{DCLK}$	23	27	30	MHz		
HSYNC	Period	t_H	1466	1728	1920	t_{DCLK}		
	Display period	t_{hdisp}	-	1440	-	t_{DCLK}		
	Back porch	t_{hbp}	3	241	255	t_{DCLK}		
	Front porch	t_{hfp}	24	47	225	t_{DCLK}		
	Pulse width	t_{hsw}	1	1	200	t_{DCLK}		
VSYNC	Period	Odd	292.5	312.5	450.5	t_H		
		Even						
	Display period	Odd	t_{vdisp}	-	288	-	t_H	
		Even						
	Back porch	Odd	t_{vbp}	3	24	34	t_H	
		Even		3.5	24.5	34.5		
	Front porch	Odd	t_{vfp}	1.5	0.5	128.5	t_H	
		Even		1	0	128		
	Pulse width	Odd	t_{vsw}	1	1	200	t_{DCLK}	
		Even						
	1 frame			585	625	901	t_H	

Fig.4 UPS052 Input Horizontal Timing Chart

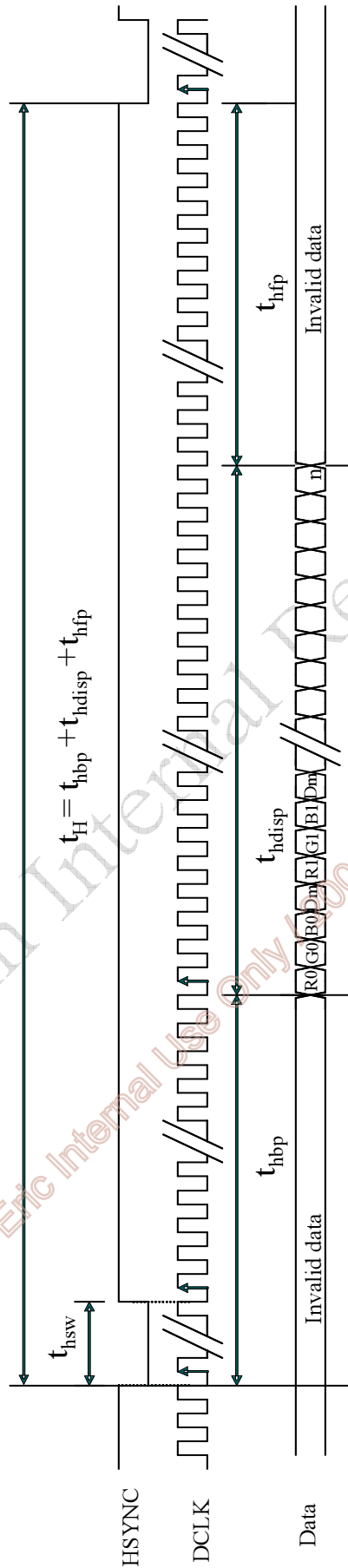
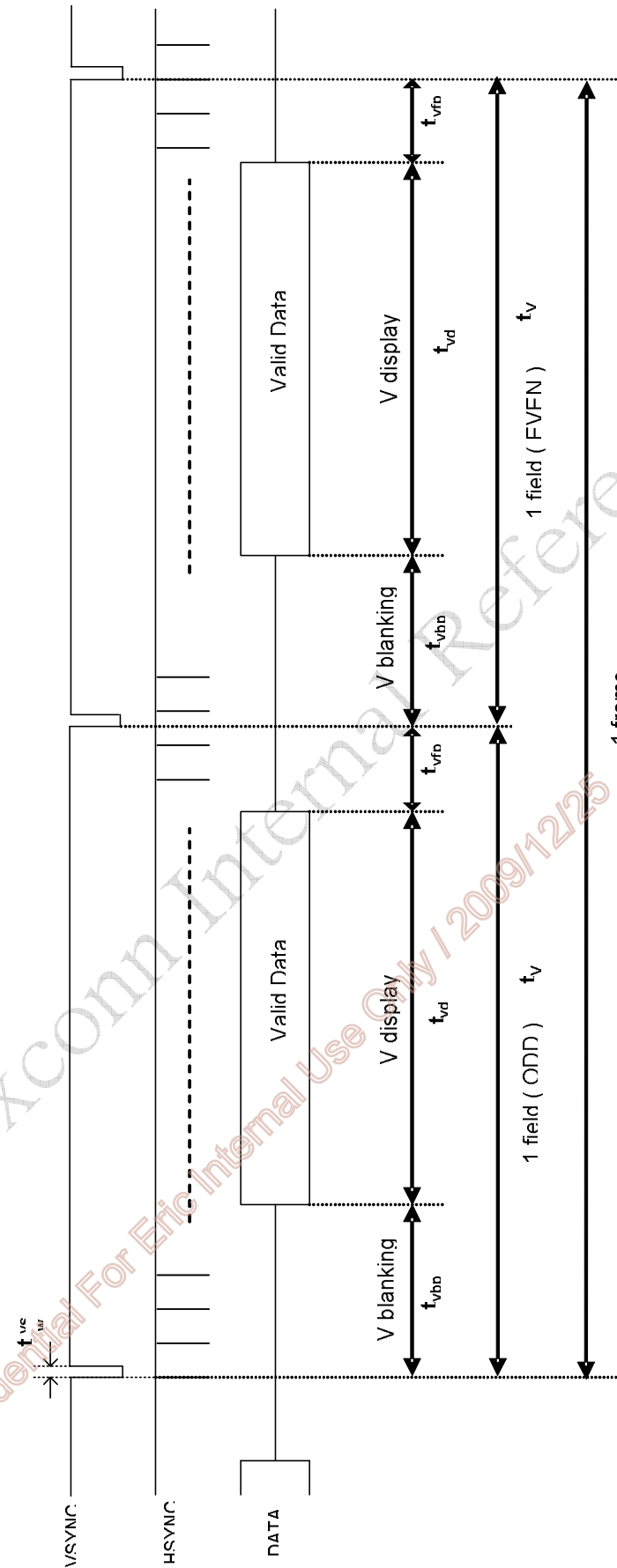

Fig.5 UPS052 Input Vertical Timing Chart



5.3 CCIR656 Timing

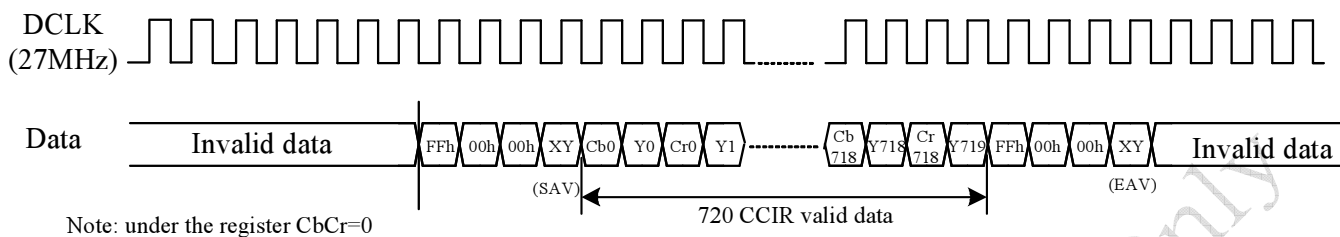

Fig.6 CCIR656 Data input format

5.3.1 CCIR656 decoding

- FF 00 00 < XY > signals are involved with HSYNC, VSYNC and Field

- <XY> encode following bits:

F=field select : F=0 for field 1, F=1 for field 2;

V=1 during vertical blanking

H=0 at SAV , H=1 at EAV ,

P3-P0=protection bits :

$P3 = V \oplus H$ $P2 = F \oplus H$ $P1 = F \oplus V$ $P0 = F \oplus V \oplus H$ \oplus : represents the exclusive-OR function

- Control is provided through “End of Video” (EAV) and “Start of Video” (SAV) timing references.

- Horizontal blanking section consists of repeating pattern 80 10 80 10

XY							
D7(MSB)	D6	D5	D4	D3	D2	D1	D0(LSB)
1	F	V	H	P3	P2	P1	P0



A025DN01 VB Product Spec	Version	0.3
	Page	22/60

5.3.2 CCIR656 NTSC

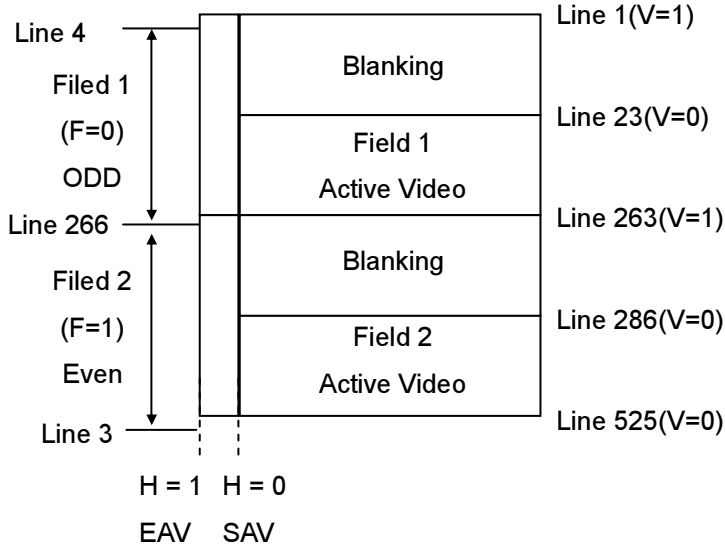

Line Number	F	V	H (EAV)	H (SAV)
1-3	1	1	1	0
4-22	0	1	1	0
23-262	0	0	1	0
263-265	0	1	1	0
266-285	1	1	1	0
286-525	1	0	1	0

	F	H	V
1	Even Field	EAV	Blanking
0	Odd Field	SAV	Active Video

5.3.3 CCIR656 PAL

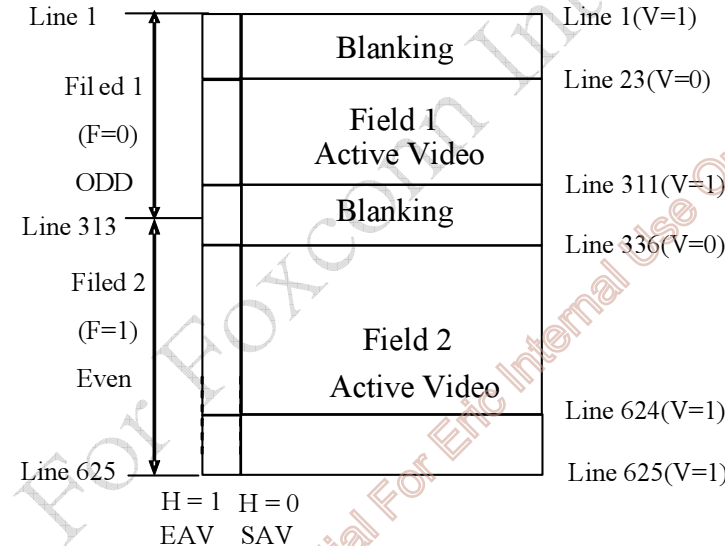

Line Number	F	V	H (EAV)	H (SAV)
1-22	0	1	1	0
23-310	0	0	1	0
311-312	0	1	1	0
313-335	1	1	1	0
335-623	1	0	1	0
624-625	1	1	1	0

	F	H	V
1	Even Field	EAV	Blanking
0	Odd Field	SAV	Active Video

5.4 YUV 720 and YUV 640 timing

5.4.1 YUV 720 mode/NTSC timing specifications (refer to Fig.7 Fig.9)

Parameter		Symbol	Min.	Typ.	Max.	Unit.	Remark	
DCLK Frequency		$1/t_{DCLK}$	23	27	30	MHz		
HSYNC	Period	t_H	1476	1716	1907	t_{DCLK}		
	Display period	t_{Hdisp}	-	1440	-	t_{DCLK}		
	Back porch	t_{Hbp}	2	240	255	t_{DCLK}		
	Front porch	t_{Hfp}	34	36	212	t_{DCLK}		
	Pulse width	t_{Hsw}	-	1	-	t_{DCLK}		
VSYNC	Period	Odd	t_V	242.5	262.5	240.5	t_H	
		Even						
	Display period	Odd	t_{Vdisp}	-	240	-	t_H	
		Even						
	Back porch	Odd	t_{Vbp}	1	21	31	t_H	
		Even		1.5	21.5	31.5		
	Front porch	Odd	t_{Vfp}	1.5	1.5	179.5	t_H	
		Even		1	1	179		
	Pulse width	Odd	t_{Vsw}	-	1	-	t_{DCLK}	
		Even						
	1 frame			485	525	901	t_H	

5.4.2 YUV 720 mode/PAL timing specifications (refer to Fig.7 Fig.9)

Parameter		Symbol	Min.	Typ.	Max.	Unit.	Remark	
DCLK Frequency		$1/t_{DCLK}$	23	27	30	MHz		
HSYNC	Period	t_H	1476	1728	1920	t_{DCLK}		
	Display period	t_{Hdisp}	-	1440	-	t_{DCLK}		
	Back porch	t_{Hbp}	2	240	255	t_{DCLK}		
	Front porch	t_{Hfp}	34	48	225	t_{DCLK}		
	Pulse width	t_{Hsw}	-	1	-	t_{DCLK}		
VSYNC	Period	Odd	t_V	292.5	312.5	450.5	t_H	
		Even						
	Display period	Odd	t_{Vdisp}	-	288	-	t_H	
		Even						
	Back porch	Odd	t_{Vbp}	3	24	34	t_H	
		Even		3.5	24.5	34.5		
	Front porch	Odd	t_{Vfp}	1.5	0.5	128.5	t_H	
		Even		1	0	128		
	Pulse width	Odd	t_{Vsw}	-	1	-	t_{DCLK}	
		Even						
	1 frame			585	625	901	t_H	

5.4.3 YUV 640 mode/NTSC timing specifications (refer to Fig.8 Fig.9)

Parameter		Symbol	Min.	Typ.	Max.	Unit.	Remark	
DCLK Frequency		$1/t_{DCLK}$	20.65	24.535	30	MHz		
HSYNC	Period	t_H	1314	1560	1907	t_{DCLK}		
	Display period	t_{hdisp}	-	1280	-	t_{DCLK}		
	Back porch	t_{hbp}	2	240	255	t_{DCLK}		
	Front porch	t_{hfp}	33	40	372	t_{DCLK}		
	Pulse width	t_{hsw}	-	1	-	t_{DCLK}		
VSYNC	Period	Odd	242.5	262.5	450.5	t_H		
		Even						
	Display period	Odd	t_{vdisp}	-	240	-	t_H	
		Even						
	Back porch	Odd	t_{vbp}	1	21	31	t_H	
		Even		1.5	21.5	31.5		
	Front porch	Odd	t_{vfp}	1.5	1.5	179.5	t_H	
		Even		1	1	179		
	Pulse width	Odd	t_{vsw}	-	1	-	t_{DCLK}	
		Even						
	1 frame			485	525	901	t_H	

5.4.4 YUV 640 mode/PAL timing specifications (refer to Fig.8 Fig.9)

Parameter		Symbol	Min.	Typ.	Max.	Unit.	Remark	
DCLK Frequency		$1/t_{DCLK}$	20.5	24.375	30	MHz		
HSYNC	Period	t_H	1314	1560	1920	t_{DCLK}		
	Display period	t_{hdisp}	-	1280	-	t_{DCLK}		
	Back porch	t_{hbp}	2	240	255	t_{DCLK}		
	Front porch	t_{hfp}	32	40	385	t_{DCLK}		
	Pulse width	t_{hsw}	-	1	-	t_{DCLK}		
VSYNC	Period	Odd	292.5	312.5	450.5	t_H		
		Even						
	Display period	Odd	t_{vdisp}	-	288	-	t_H	
		Even						
	Back porch	Odd	t_{vbp}	3	24	34	t_H	
		Even		3.5	24.5	34.5		
	Front porch	Odd	t_{vfp}	1.5	0.5	128.5	t_H	
		Even		1	0	128		
	Pulse width	Odd	t_{vsw}	-	1	-	t_{DCLK}	
		Even						
	1 frame			585	625	901	t_H	

Fig.9 YUV Input Vertical Timing Chart

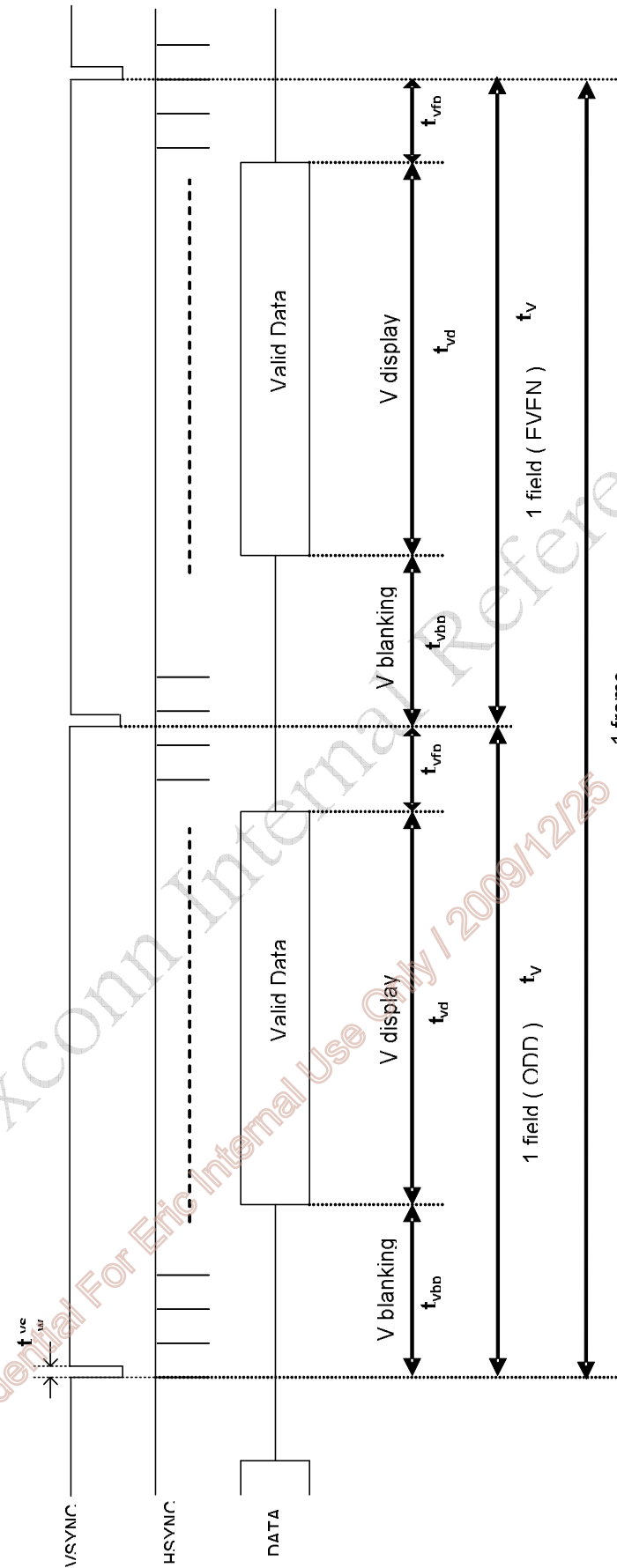



A025DN01 VB Product Spec	Version	0.3
	Page	27/60

5.5 CCIR656/YUV 720/YUV 640 to RGB conversion

$$R_n = 1.164 * [(Y_{2n-1} + Y_{2n}) / 2 - 16] + 1.596 * (C_{rn} - 128)$$

$$G_n = 1.164 * [(Y_{2n-1} + Y_{2n}) / 2 - 16] - 0.813 * (C_{rn} - 128) - 0.392 * (C_{bn} - 128)$$

$$B_n = 1.164 * [(Y_{2n-1} + Y_{2n}) / 2 - 16] + 2.017 * (C_{bn} - 128)$$

Where Y:16~235 C_r:16~240 C_b:16~240

For Foxconn Internal Reference Only
AUO Confidential For Eric Internal Use Only / 2009/12/25

6. Serial control interface AC characteristic

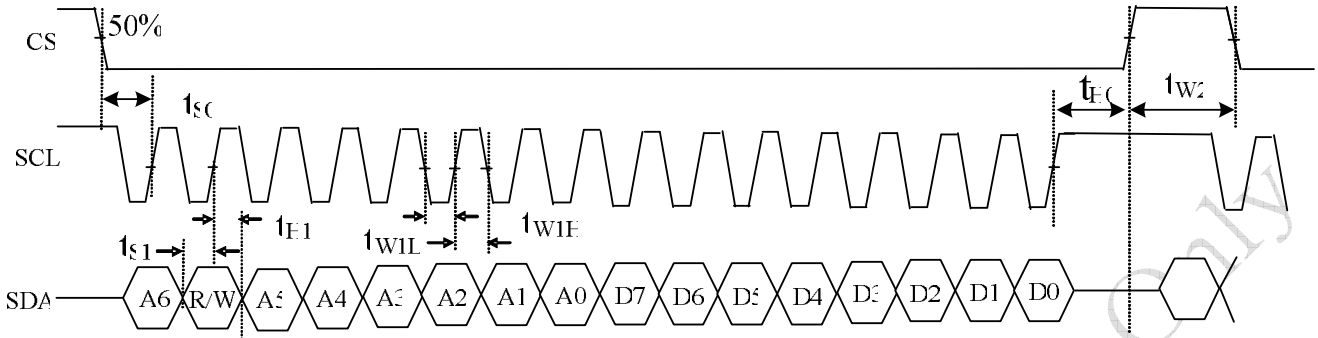

Item	Symbol	Min	Typical	Max	Unit
CS input setup Time	t_{S0}	50	-	-	ns
Serial data input setup Time	t_{S1}	50	-	-	ns
CS input hold Time	t_{H0}	50	-	-	ns
Serial data input hold Time	t_{H1}	50	-	-	ns
SCL pulse low width	t_{W1L}	50	-	-	ns
SCL pulse high width	t_{W1H}	50	-	-	ns
CS pulse high width	t_{W2}	400	-	-	ns

6.1 Timing chart

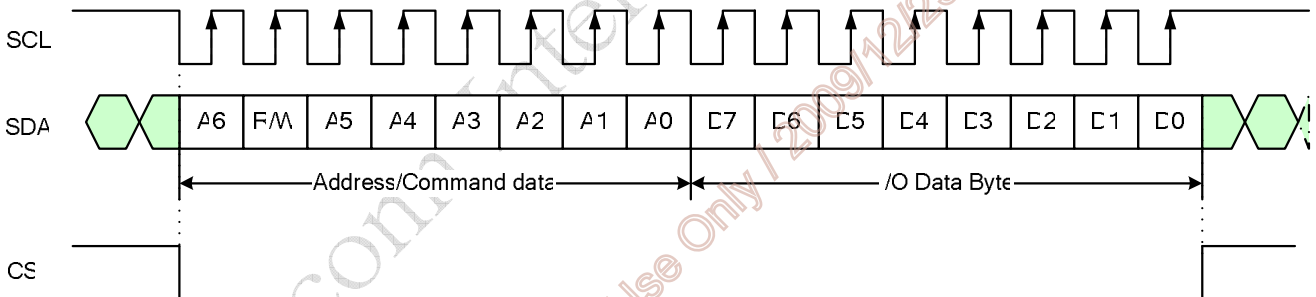

- Each serial command consists of 16 bits of data which is loaded one bit a time at the rising edge of serial clock SCL.
- Command loading operation starts from the falling edge of CS and is completed at the next rising edge of CS.
- The serial control block is operational after power on reset, but commands are established by the VSYNC signal. If command is transferred multiple times for the same register, the last command before the VSYNC signal is valid.
- If less than 16 bits of SCL are input while CS is low, the transferred data is ignored.
- If 16 bits or more of SCL are input while CS is low, the previous 16 bits of transferred data after the rising edge of CS pulse are valid data.
- Serial block operates with the SCL clock.
- Serial data can be accepted in the standby (power save) mode.



A025DN01 VB Product Spec	Version	0.3
	Page	29/60

6.2 The configuration of serial data at SDA terminal is at below

MSB								LSB							
A6	R/W	A5	A4	A3	A2	A1	A0	D7	D6	D5	D4	D3	D2	D1	D0
Address		Address						DATA							

R/W: Establishes the Read mode when set to '1', and the Write mode when set to '0'.

Write Mode:

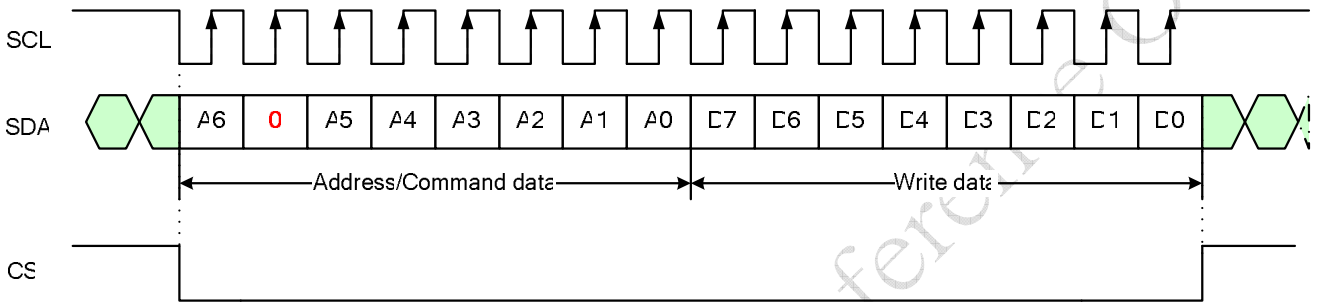



A025DN01 VB Product Spec	Version	0.3
	Page	30/60

6.3 Register table

No.	Register address								Register data (default setting)								MSB	LSB
	A6	R/W	A5	A4	A3	A2	A1	A0	D7	D6	D5	D4	D3	D2	D1	D0		
R0	0	0	0	0	0	0	0	0	Y_CbCr (0)	CCIR601 (0)	x	x	VCAC (0)	VCOM_AC (011)				
R1	0	0	0	0	0	0	0	1	VCDCE (1)	0	VCOM_DC (0Ah)							
R3	0	0	0	0	0	0	1	1	Brightness (40h)									
R4	0	0	0	0	0	1	0	0	Narrow (0)	YUV (0)	SEL (00)	NTSC/PAL (10)		VDIR (1)	HDIR (1)			
R5	0	0	0	0	0	1	0	1	DRV_FREQ (0)	GRB (1)	PFM_DUTY (011)		SHDB2 (1)	SHDB1 (1)	STB (0)			
R6	0	0	0	0	0	1	1	0	HBLK_EN (0)	LED_Current (00)	VBLK (15h)							
R7	0	0	0	0	0	1	1	1	HBLK(46h)									
R8	0	0	0	0	1	0	0	0	BL_DRV (00)	x	x	x	0	0	0			
R12	0	0	0	0	1	1	0	0	PAIR (00)	x	CbCr (0)	x	Vdpol (1)	Hdpol (1)	DCLKpol (0)			
R13	0	0	0	0	1	1	0	1	CONTRAST_RGB (40h)									
R14	0	0	0	0	1	1	0	1	x	SUB-CONTRAST_R (40h)								
R15	0	0	0	0	1	1	1	1	x	SUB-BRIGHTNESS_R (40h)								
R16	0	0	0	1	0	0	0	0	x	SUB-CONTRAST_B (40h)								
R17	0	0	0	1	0	0	0	1	x	SUB-BRIGHTNESS_B (40h)								
R21	0	0	0	1	0	1	0	1	LED_ON_CYCLE (0111)				LED_ON_RATIO (1111)					
R22	0	0	0	1	0	1	1	0	x	X	x	x	x	GAMMA2.2 (1)	x	x		
R23	0	0	0	1	0	1	1	1	x	x	GMA_V8 (01)		x	x	GMA_V4 (01)			
R24	0	0	0	1	1	0	0	0	x	x	GMA_V25 (10)		x	x	GMA_V16 (10)			
R25	0	0	0	1	1	0	0	1	x	x	GMA_V48 (10)		x	x	GMA_V36 (10)			
R26	0	0	0	1	1	0	1	0	x	x	GMA_V60 (10)		x	x	GMA_V55 (10)			

Note: 1. "x" => please set to '0'.

6.4 Register description

R0:

No.	Register address								Register data							MSB	LSB		
	A6	R/W	A5	A4	A3	A2	A1	A0	D7	D6	D5	D4	D3	D2	D1	D0			
R0	0	0	0	0	0	0	0	0	Y_CbCr(0)	CCIR601 (0)	x	x	VCAC(0)	VCOM_AC(011)					

VCOM_AC: Common voltage AC level selection (deviation $\pm 0.1V$)

VCOM_AC			VCAC	Voltage (V)
D2	D1	D0	D3	
0	0	0	0	3.6
0	0	0	1	3.7
0	0	1	0	3.8
0	0	1	1	3.9
0	1	0	0	4.0
0	1	0	1	4.1
0	1	1	0	4.2(Default)
0	1	1	1	4.3
1	0	0	0	4.4
1	0	0	1	4.5
1	0	1	0	4.6
1	0	1	1	4.7
1	1	X	X	4.8

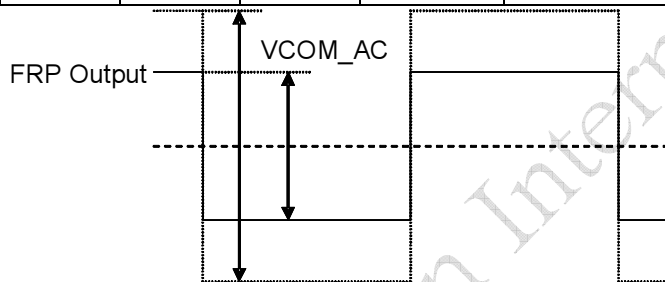

CCIR601: CCIR601 input timing selection

CCIR601	Function
0(Default)	Disable CCIR601 (Default)
1	Enable CCIR601. (Please refer to the table of R4(SEL) for detail description)

Y_CbCr: Y & CbCr exchange position (only valid for 8-bit input YUV640 / YUV720)

	CbCr(R12[4])='0'	CbCr(R12[4])='1'
Y_CbCr='0' (Default)	Cb0 Y0 Cr0 Y1 Cb2 Y2 Cr2 Y3	Cr0 Y0 Cb0 Y1 Cr2 Y2 Cb2 Y3
Y_CbCr='1'	Y0 Cb0 Y1 Cr0 Y2 Cb2 Y3 Cr2	Y0 Cr0 Y1 Cb0 Y2 Cr2 Y3 Cb2

R1:

No	Register address								Register data							
	A6	R/W	A5	A4	A3	A2	A1	A0	D7	D6	D5	D4	D3	D2	D1	D0
R1	0	0	0	0	0	0	0	1	VCDCE (1)	x	VCOM_DC (21h)					

VCOM_DC: Common voltage DC level selection (20mV/step)

D5~D0	VCOM DC level (V)
00h	0.1
:	:
0Ah(Default)	0.30(Default)
:	:
3Fh	1.36

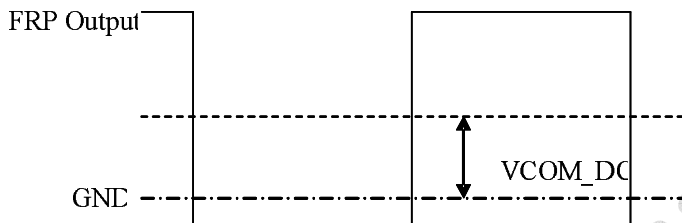

VCDCE: VCOM_DC function enable setting

VCDCE	Function
0	VCOM_DC function disable. The COMDC pin is Hi-Z.
1	VCOM_DC function enable. The COMDC voltage follows VCOM_DC setting. (Default)

R3:

No.	Register address								Register data							
	A6	R/W	A5	A4	A3	A2	A1	A0	D7	D6	D5	D4	D3	D2	D1	D0
R3	0	0	0	0	0	0	1	1	Brightness (40h)							

BRIGHTNESS: RGB bright level setting, setting accuracy: 1 step / bit

D7 ~ D0	Brightness gain
00h	Dark (-64)
40h(Default)	Center (0) (Default)
FFh	Bright (+191)



A025DN01 VB Product Spec	Version	0.3
	Page	33/60

R4:

No.	Register address								Register data							
	A6	R/W	A5	A4	A3	A2	A1	A0	D7	D6	D5	D4	D3	D2	D1	D0
R4	0	0	0	0	0	1	0	0	Narrow(0)	YUV(0)	SEL(00)		NTSC/PAL(10)		VDIR(1)	HDIR(1)

HDIR: Horizontal scan direction setting

HDIR	Function
0	Right to left scan
1	Left to right scan (Default)

VDIR: Vertical scan direction setting

VDIR	Function
0	Down to up scan
1	Up to down scan (Default)

NTSC/PAL: NTSC or PAL input mode selection (for UPS052 input timing)

NTSC/PAL		Mode
D3	D2	
0	0	PAL
0	1	NTSC
1	X	Auto detection (Default)

SEL: Input data timing format selection

CCIR601	YUV	SEL		INPUT TIMING FORMAT
		D5	D4	
0	0	0	0	UPS051 (Default)
0	0	0	1	UPS052 320 × 240
0	0	1	X	UPS052 360 × 240
0	1	1	0	CCIR656
1	1	0	X	YUV 640(*)
1	1	1	0	YUV 720(*)

(*)Please refer to YUV640/YUV720 horizontal timing spec for detailed description.

A025DN01 VB Product Spec	Version	0.3
	Page	34/60

YUV: YUV (CCIR656, YUV640, YUV720) or RGB input selection

YUV	Function
0	RGB input (Default)
1	CCIR656 / YUV640 / YUV720 input.

When this command is sent to ASIC, it will be executed immediately

Narrow: Normal display and Narrow display selection.

Narrow	Function
0	Normal display (Default)
1	Narrow Display



Narrow=0



Narrow=1



A025DN01 VB Product Spec	Version	0.3
	Page	35/60

R5:

No	Register address								Register data							MSB	LSB
	A6	R/W	A5	A4	A3	A2	A1	A0	D7	D6	D5	D4	D3	D2	D1		
R5	0	0	0	0	0	1	0	1	DRV_FREQ(0)	GRB(1)	PFM_DUTY(011)		SHDB2(1)	SHDB1(1)	STB(0)		

STB: Standby (Power saving) mode setting

STB	Function
0	Standby mode (Default)
1	Normal operation

SHDB1: Shut down for back light power converter

SHDB1	Function
0	The back light power converter is off
1	The back light power converter is controlled by power on/off sequence (Default)

SHDB2: Shut down for VGH/VGL charge pump

SHDB2	Function
0	VGH/VGL charge pump is always off
1	VGH/VGL charge pump is controlled by power on/off sequence (Default)

PFM_DUTY: PFM duty cycle selection for back light power converter

PFM_DUTY			Function
D5	D4	D3	PFM duty cycle
0	0	0	50%
0	0	1	60%
0	1	0	65%
0	1	1	70%(Default)
1	0	0	75%
1	0	1	80%
1	1	0	85%
1	1	1	90%

GRB: Register reset setting

GRB	Function
0	Reset all registers to default value
1	Normal operation (Default)

DRV_FREQ: DRV signal frequency setting

DRV_FREQ	DRV frequency
0(Default)	DCLK / 64
1	DCLK / 128



A025DN01 VB Product Spec	Version	0.3
	Page	36/60

R6:

No	Register address								Register data							MSB	LSB
	A6	R/W	A5	A4	A3	A2	A1	A0	D7	D6	D5	D4	D3	D2	D1		
R6	0	0	0	0	0	1	1	0	HBLK_EN(0)	LED_Current(00)	VBLK(15h)						

VBLK: Vertical blanking setting

UPS051, UPS052, YUV640 and YUV720 NTSC mode

D4 ~ D0	VBLK	Unit
01h	1	H (line)
15h	21(Default)	
1Fh	31	

CCIR656 NTSC mode

D4 ~ D0	VBLK	Unit
01h	1	H (line)
16h	22(Default)	
1Fh	31	

UPS052, CCIR656 and YUV640 and YUV720 PAL mode(Vertical blanking + 3)

D4 ~ D0	VBLK	Unit
00h	3	H (line)
15h	24(Default)	
1Fh	34	

Note: V-blanking must be adjusted based on the input data.

LED_CURRENT: adjust LED current

DC-DC feedback voltage

D6	D5	Feedback Threshold voltage
0	0	0.6V(20mA) (default)
0	1	0.75V(25mA)
1	0	0.45V(15mA)
1	1	0.3V(10mA)



A025DN01 VB Product Spec	Version	0.3
	Page	37/60

R6 & R7:

No	Register address								Register data							
	A6	R/W	A5	A4	A3	A2	A1	A0	D7	D6	D5	D4	D3	D2	D1	D0
R6	0	0	0	0	0	1	1	0	HBLK_EN(0)	LED_Current(00)	VBLK(15h)					
R7	0	0	0	0	0	1	1	1	HBLK(46h)							

HBLK_EN & HBLK: Horizontal blanking setting

HBLK_EN	HBLK(D7~D0)	HBLK	Unit	Remark
x	32h	50	DCLK(*)	UPS051
x	46h	70(Default)		
x	FFh	255		
x	x	241(fixed)	DCLK(*)	UPS052
1	02h~FF	2~255	DCLK(*)	YUV640, YUV720
0	xxh	240(fixed)	DCLK(*)	
1	02h ~ FFh	2 ~ 255	DCLK(*)	

*The frequency of DCLK is different under different input timing.

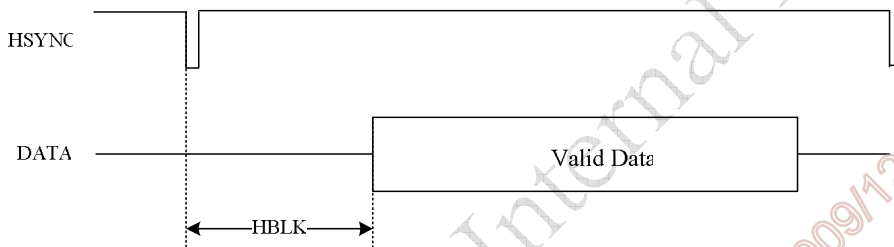

R8:

No.	Register address								Register data							
	A6	R/W	A5	A4	A3	A2	A1	A0	D7	D6	D5	D4	D3	D2	D1	D0
R8	0	0	0	0	1	0	0	0	BL_DRV(00)	x	x	x	x	x	x	

BL_DRV: Backlight driving capability setting

D7	D6	BL_DRV capability
0	0	Normal capability (Default)
0	1	2 times the Normal capability
1	0	4 times the Normal capability
1	1	8 times the Normal capability



A025DN01 VB Product Spec	Version	0.3
	Page	38/60

R12:

No.	Register address								Register data							LSB
	A6	R/W	A5	A4	A3	A2	A1	A0	D7	D6	D5	D4	D3	D2	D1	D0
R12	0	0	0	0	1	1	0	0	PAIR(00)	x	CbCr(0)	x	Vdpol(1)	Hdpol(1)	DCLKpol(0)	

DCLKpol: DCLK polarity selection

DCLKpol	Function
0	Positive polarity (Default)
1	Negative polarity

HDpol: HSYNC polarity selection

HDpol	Function
0	Positive polarity
1	Negative polarity (Default)

VDpol: VSYNC polarity selection

VDpol	Function
0	Positive polarity
1	Negative polarity (Default)

HDpol=1, VDpol=1, DCLKpol=0

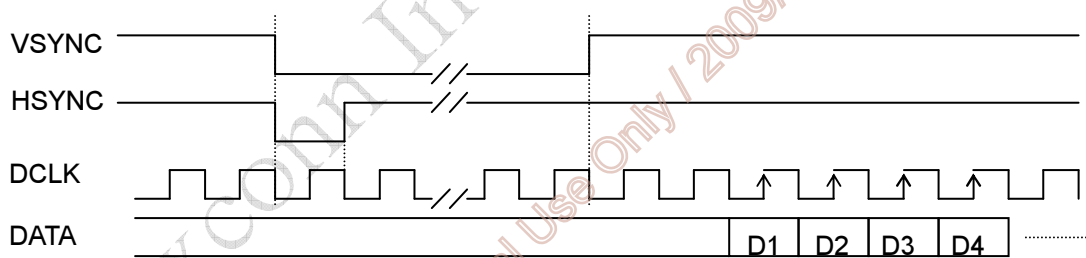

HDpol=0, VDpol=0, DCLKpol=1

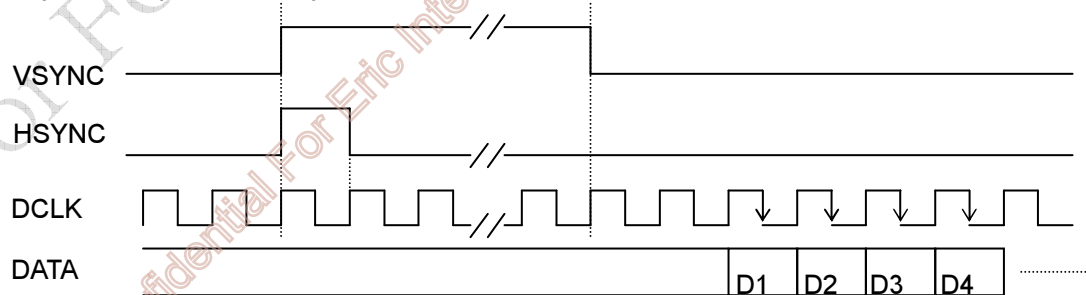



A025DN01 VB Product Spec	Version	0.3
	Page	39/60

CbCr: Cb & Cr exchange position, (Please refer to the table of R0(Y_CbCr) for detail description)

CbCr='0'		Cb0	Y0	Cr0	Y1	Cb2	Y2	Cr2	Y3
CbCr='1'		Cr0	Y0	Cb0	Y1	Cr2	Y2	Cb2	Y3

PAIR: Vertical start time setting for Odd/Even frame

UPS051 / UPS052 NTSC / UPS052 PAL (*)

PAIR		VBLK		Unit
D7	D6	ODD/EVEN		
x	0	21/21(Default)		H (line)
x	1	21/20		

CCIR656/YUV640/YUV720 NTSC/PAL (**)

PAIR		VBLK		Unit
D7	D6	ODD/EVEN		
0	0	22/22		H (line)
0	1	22/23		
1	0	23/22		
1	1	23/23		

(*)The typical value of VBLK of UPS052 PAL(24 H) is different than UPS051/UPS052 NTSC(21H).

(**) The typical value of VBLK of CCIR656 PAL(24 H) is different than CCIR656 NTSC(22H).

Note: V-blanking must be adjusted based on the input data.

For example:

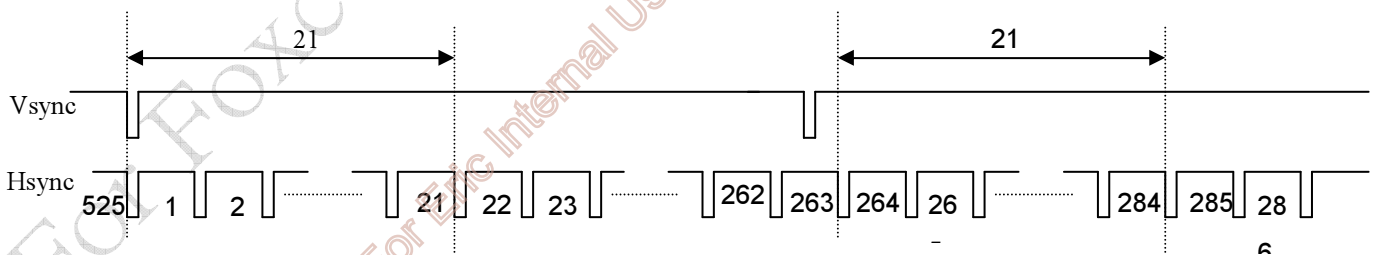

		PAIR=0		PAIR=1	
Field	Line	START	END	START	END
	ODD		22	261	22
EVEN		285	524	284	523

This table is based on VBLK=21.



A025DN01 VB Product Spec	Version	0.3
	Page	40/60

R13:

No.	Register address								Register data								MSB	LSB
	A6	R/W	A5	A4	A3	A2	A1	A0	D7	D6	D5	D4	D3	D2	D1	D0		
R13	0	0	0	0	1	1	0	1	CONTRAST_RGB(40h)									

CONTRAST_RGB: RGB contrast level setting, the gain changes (1/64) / bit

D7 ~ D0	Contrast gain
00h	0
40h	1(Default)
FFh	3.984

R14~R17:

No.	Register address								Register data								MSB	LSB
	A6	R/W	A5	A4	A3	A2	A1	A0	D7	D6	D5	D4	D3	D2	D1	D0		
R14	0	0	0	0	1	1	0	1	x	SUB-CONTRAST_R(40h)								
R16	0	0	0	1	0	0	0	0	X	SUB-CONTRAST_B(40h)								

SUB-CONTRAST: R/B sub-contrast level setting, the gain changes (1/256) / bit

D6 ~ D0	Brightness gain
00h	0.75
40h	1(Default)
7Fh	1.246

No.	Register address								Register data								MSB	LSB
	A6	R/W	A5	A4	A3	A2	A1	A0	D7	D6	D5	D4	D3	D2	D1	D0		
R15	0	0	0	0	1	1	1	1	X	SUB-BRIGHTNESS_R(40h)								
R17	0	0	0	1	0	0	0	1	X	SUB-BRIGHTNESS_B(40h)								

SUB-BRIGHTNESS: R/B sub-bright level setting, setting accuracy: 1 step / bit

D6 ~ D0	Brightness gain
00h	Dark (-64)
40h	Center (0)(Default)
7Fh	Bright (+63)



A025DN01 VB Product Spec	Version	0.3
	Page	41/60

R21:

No.	Register address								Register data								LSB
	A6	R/W	A5	A4	A3	A2	A1	A0	D7	D6	D5	D4	D3	D2	D1	D0	
R21	0	0	0	1	0	1	0	1	LED_ON_CYCLE (0111)				LED_ON_RATIO (1111)				

LED_ON_RATIO: Set the active ratio of enable signal, and we can use it to adjust brightness of the LEDs.

LED_ON_RATIO				Value
D3	D2	D1	D0	
0	0	0	0	1/16
0	0	0	1	2/16
0	0	1	0	3/16
0	0	1	1	4/16
0	1	0	0	5/16
0	1	0	1	6/16
0	1	1	0	7/16
0	1	1	1	8/16
1	0	0	0	9/16
1	0	0	1	10/16
1	0	1	0	11/16
1	0	1	1	12/16
1	1	0	0	13/16
1	1	0	1	14/16
1	1	1	0	15/16
1	1	1	1	16/16(Default)

LED_ON_CYCLE : Set the cycle of enable signal , and we can use it to adjust brightness of the LEDs.

LED_ON_CYCLE				Value
D7	D6	D5	D4	
0	0	0	0	1
0	0	0	1	2
0	0	1	0	3
0	0	1	1	4
0	1	0	0	5
0	1	0	1	6
0	1	1	0	7
0	1	1	1	8(Default)
1	0	0	0	9
1	0	0	1	10
1	0	1	0	11
1	0	1	1	12
1	1	0	0	13
1	1	0	1	14
1	1	1	0	15
1	1	1	1	16

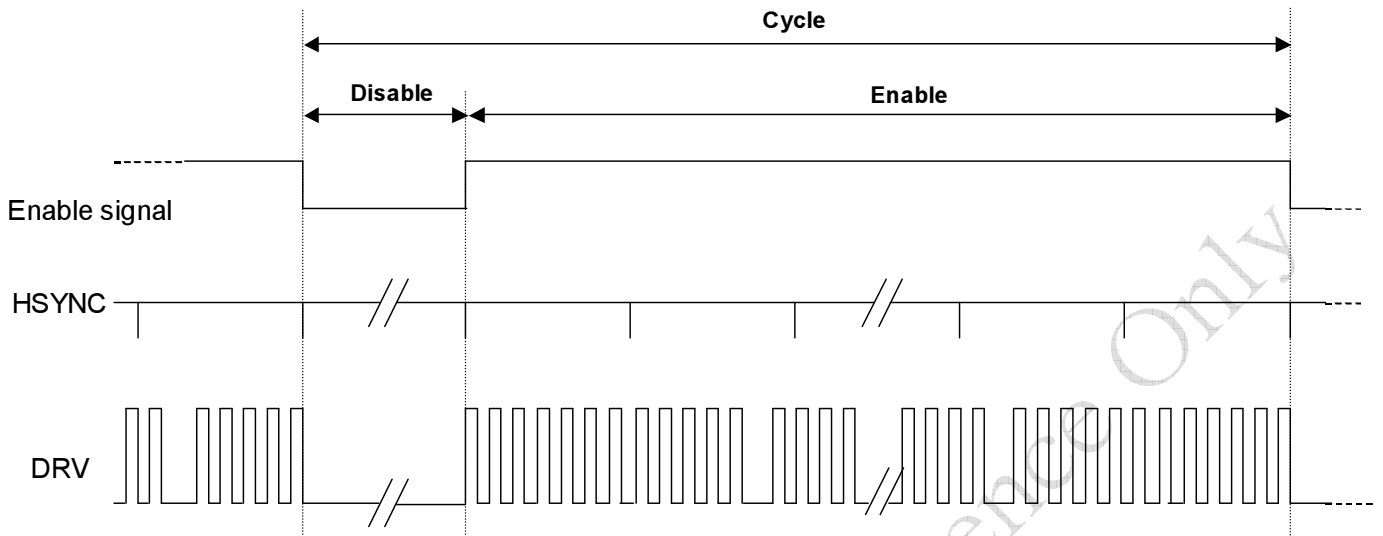

$$16 * \text{LED_ON_CYCLE} = \text{LED_ON_CYCLE} * (\text{LED_ON_RATIO} * 16) + \text{LED_ON_CYCLE} * (16 - \text{LED_ON_RATIO} * 16)$$

(Cycle)

(Enable)

(Disable)

Unit : HSYNC

for example:

LED_ON_RATIO is "1001", and LED_ON_CYCLE is "0111", then:

Cycle = $16 * 8 = 128$ (HSYNC)

Enable = $8 * ((10/16) * 16) = 80$ (HSYNC)

Disable = $8 * (16 - (10/16) * 16) = 48$ (HSYNC) → 62.5% on

R22:

No.	Register address								Register data								MSB		LSB	
	A6	R/W	A5	A4	A3	A2	A1	A0	D7	D6	D5	D4	D3	D2	D1	D0				
R22	0	0	0	1	0	1	1	0	x	x	x	x	x	GAMMA setting(1)		x	x			

GAMMA setting: Select auto or manual gamma setting

GAMMA setting	Description
0	Manual set gamma by R23 ~ R26.
1	Auto set to default gamma (Close to 2.2) (Default).

R23 ~ R26:

No.	Register address								Register data							
	A6	R/W	A5	A4	A3	A2	A1	A0	MSB				LSB			
									D7	D6	D5	D4	D3	D2	D1	D0
R23	0	0	0	1	0	1	1	1	x	x	GMA_V8(01)		x	x	GMA_V4(01)	
R24	0	0	0	1	1	0	0	0	x	x	GMA_V25 (10)		x	x	GMA_V16 (10)	
R25	0	0	0	1	1	0	0	1	x	x	GMA_V48 (10)		x	x	GMA_V36 (10)	
R26	0	0	0	1	1	0	1	0	x	x	GMA_V60 (10)		x	x	GMA_V55 (10)	

8 adjustable points

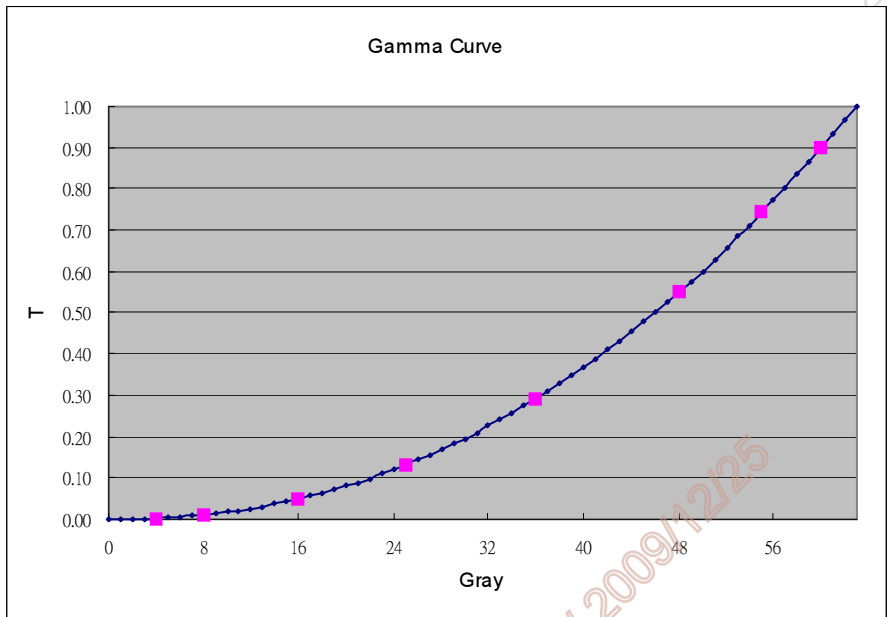

C. Optical specification (Note 1, Note 2, Note 3)

Item	Symbol	Condition	Min.	Typ.	Max.	Unit	Remark		
Response time	Rise	$\theta = 0^\circ$	-	15	25	ms	Note 4		
	Fall							Tf	20
Contrast ratio	CR	At optimized viewing angle	200	300	-		Note 5,6		
Viewing angle	Top	$CR \geq 10$	10	20		deg.	Note 7		
	Bottom							30	40
	Left							35	45
	Right							35	45
Brightness *	Y_L	$\theta = 0^\circ$	200	250	-	cd/m^2	Note 8		
White chromaticity	x	$\theta = 0^\circ$	(0.25)	(0.30)	(0.35)				
	y	$\theta = 0^\circ$	(0.27)	(0.32)	(0.37)				

Note 1. Ambient temperature = 25°C.

Note 2. To be measured in the dark room.

Note 3. To be measured on the center area of panel with a field angle of 1° by Topcon luminance meter BM-7, after 10 minutes operation.

Note 4. Definition of response time:

The output signals of photo detector are measured when the input signals are changed from "black" to "white" (falling time) and from "white" to "black" (rising time), respectively.

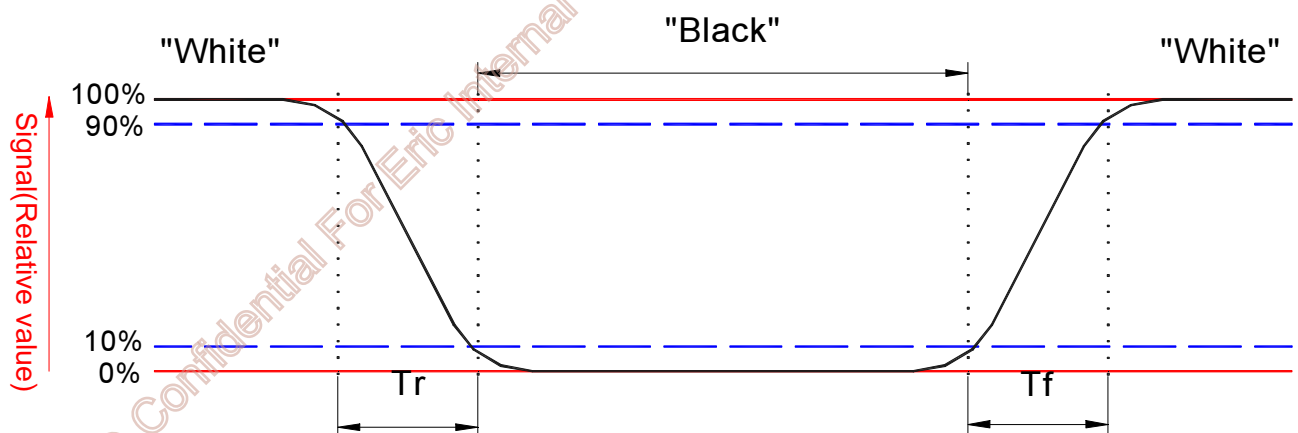

The response time is defined as the time interval between the 10% and 90% of amplitudes. Refer to figure as below.

A025DN01 VB Product Spec	Version	0.3
	Page	45/60

Note 5. Definition of contrast ratio:

Contrast ratio is calculated with the following formula.

$$\text{Contrast ratio (CR)} = \frac{\text{Photo detector output when LCD is at "White" state}}{\text{Photo detector output when LCD is at "Black" state}}$$

Note 6. White $V_i = V_{i50} \mp 1.5V$

Black $V_i = V_{i50} \pm 2.0V$

" \pm " Means that the analog input signal swings in phase with COM signal.

" \mp " Means that the analog input signal swings out of phase with COM signal.

V_{i50} : The analog input voltage when transmission is 50%

The 100% transmission is defined as the transmission of LCD panel when all the input terminals of module are electrically opened.

Note 7. Definition of viewing angle:

Refer to figure as below.

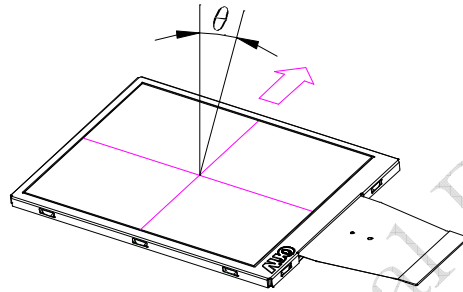

Note 8. Measured at the center area of the panel when all the input terminals of LCD panel are electrically opened with LED driving current = 25mA.

Note 9. Color Filter Arrangement

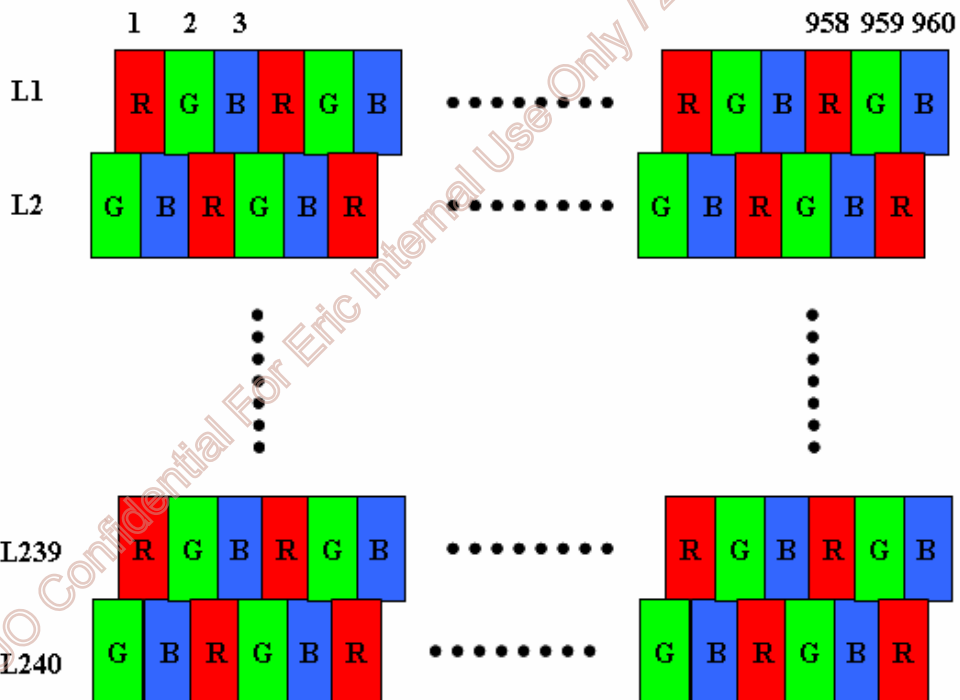

D. Reliability test items

No.	Test items	Conditions	Remark
1	High temperature storage	Ta= 70°C 240Hrs	
2	Low temperature storage	Ta= -25°C 240Hrs	
3	High temperature operation	Ta= 60°C 240Hrs	
4	Low temperature operation	Ta= 0°C 240Hrs	
5	High temperature and high humidity	Ta= 60°C . 90% RH 240Hrs	Operation
6	Heat shock	0°C~60°C/50 cycle 2Hrs/cycle	Non-operation
7	Electrostatic discharge	Air-mode : +/- 8kV Contact-mode : +/- 4kV	Note.2 Base on AUO's standard testing
8	Vibration	Frequency range : 10~55Hz Stoke : 1.5mm Sweep : 10~55Hz~10Hz 2 hours for each direction of X,Y,Z (6 hours for total)	Non-operation JIS C7021, A-10 condition A
9	Mechanical shock	100G . 6ms, ±X,±Y,±Z 3 times for each direction	Non-operation JIS C7021, A-7 condition C
10	Vibration (with carton)	Random vibration: 0.015G ² /Hz from 5~200Hz -6dB/Octave from 200~500Hz	IEC 68-34
11	Drop (with carton)	Height: 60cm 1 corner, 3 edges, 6 surfaces	

Note 1: Ta: Ambient temperature.

Note 2. ESD Testing Flow as the below

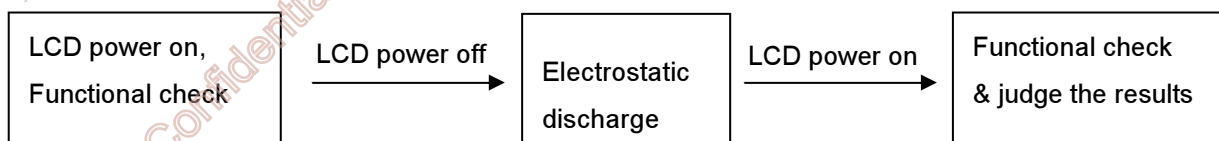

Note 3. ESD testing method.

1. Ambient: 24~26□, 56~65%RH

A025DN01 VB Product Spec	Version	0.3
	Page	47/60

2. Instruments: Noiseken ESS-2000,
3. Operation System: "CX40FL-B" and adapter "A027DN01 VB"
4. Test Mode: Operating mode, test pattern: colorbar+8Gray scale
5. Test Method:
 - a. Contact Discharge: Max $\pm 20\text{KV}$, 150pF(330 Ω) 1sec, 5 points, 10 times/point
 - b. Air Discharge: Max $\pm 20\text{KV}$, 150pF(330 Ω) 1sec, 5 points, 10 times/point
6. Test point:

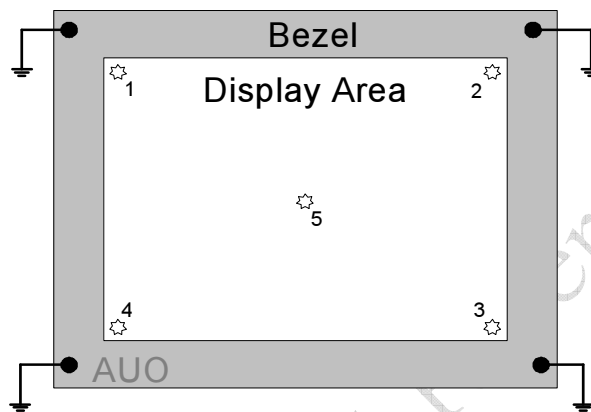

7. The metal casing is connected to ground (0V) at four corners.
8. All register commands are repeating transfer

E. Packing form

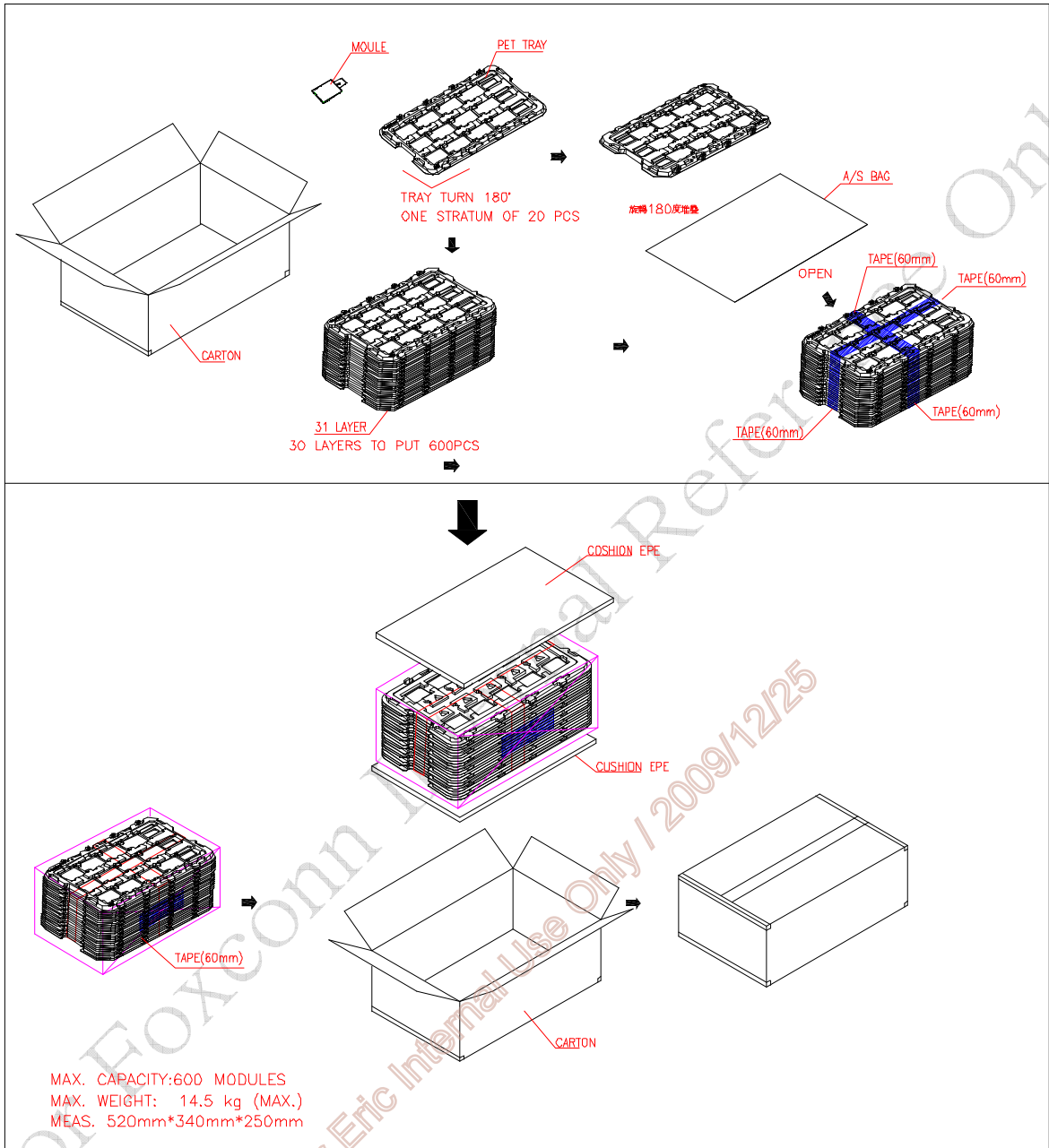

F. Outline dimension

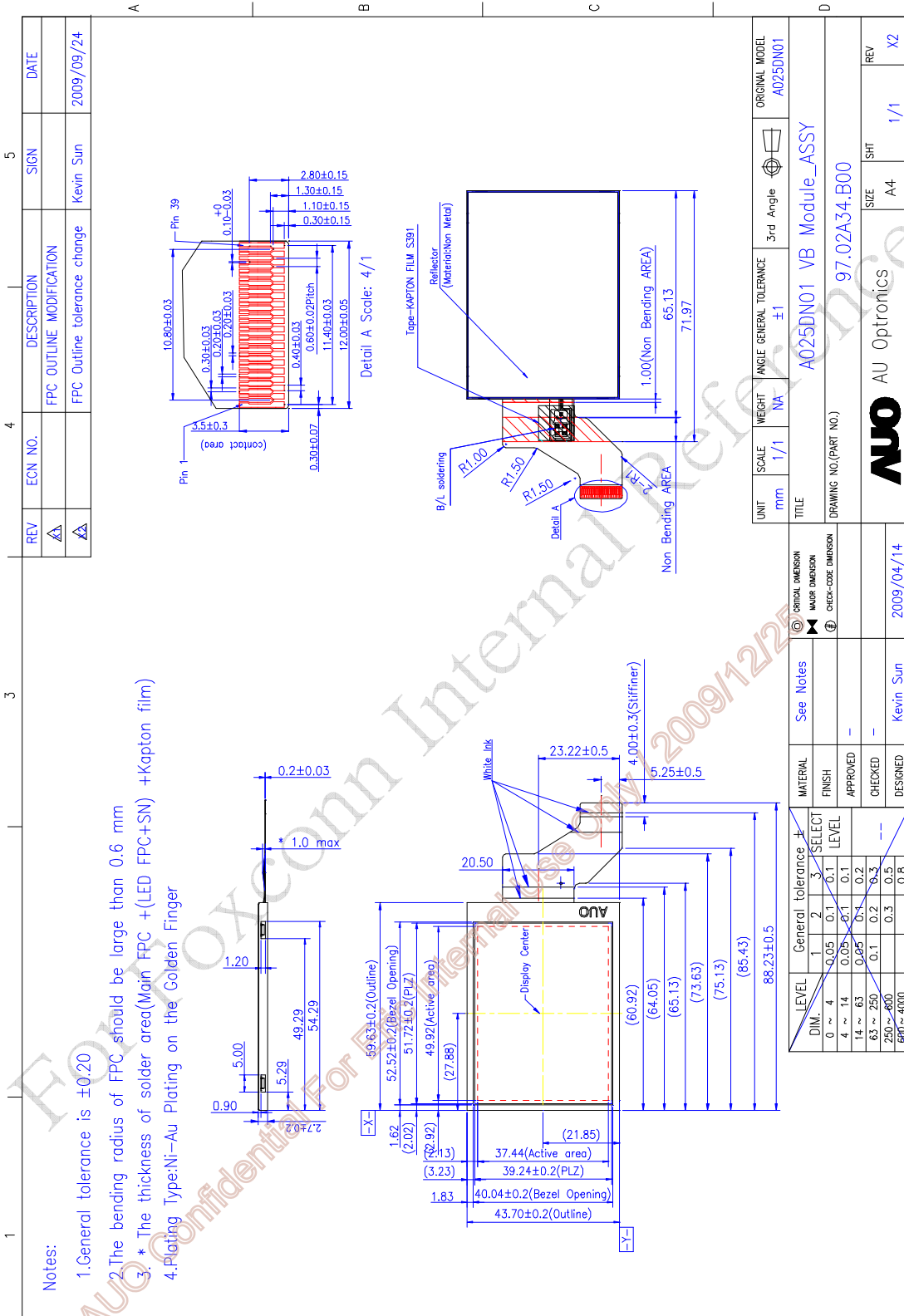

Notes:

1. General tolerance is ± 0.20
2. The bending radius of FPC should be large than 0.6 mm
3. * The thickness of solder area (Main FPC + (LED FPC+SN) +Kapton film)
4. Plating Type: Ni-Au Plating on the Golden Finger

This drawing is the property of AU Optronics Corp. and should not be disclosed to any third party without prior permission of AU Optronics Corp.

G. Application note

1. Application circuit

1.1 With internal LED driver circuit

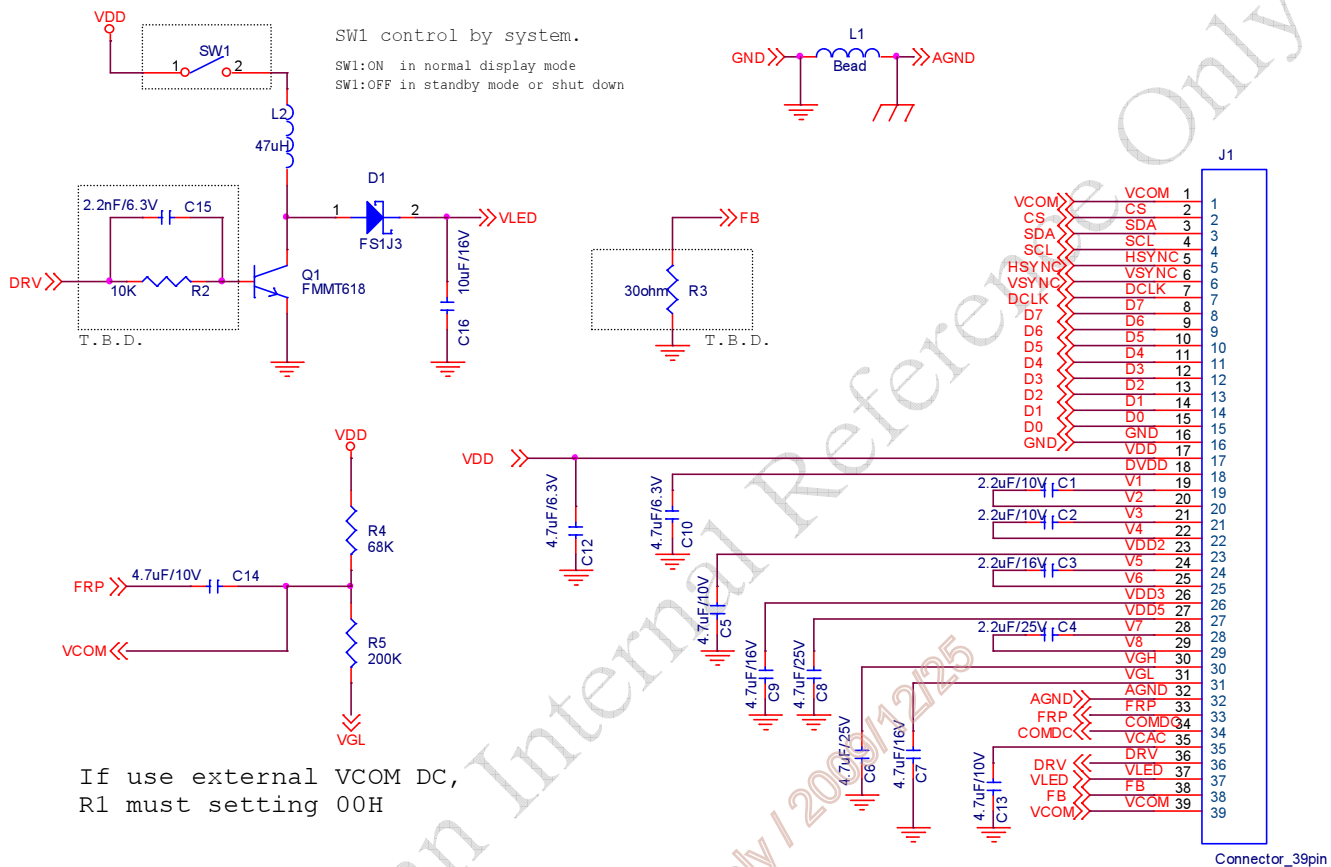

Note1: Use internal LED driver must set R5[1](SHDB1)= "1".

Note2: If use external VCOM DC, R1 must setting 00H to disable internal VCOM_DC function.

Note3: R4 resistor :

Depending on flick patterns in customer' site, customer can choose a best value to minimize flick issue.

AUO recommends values from 60K to 68K.

1.2 With external LED driver circuit

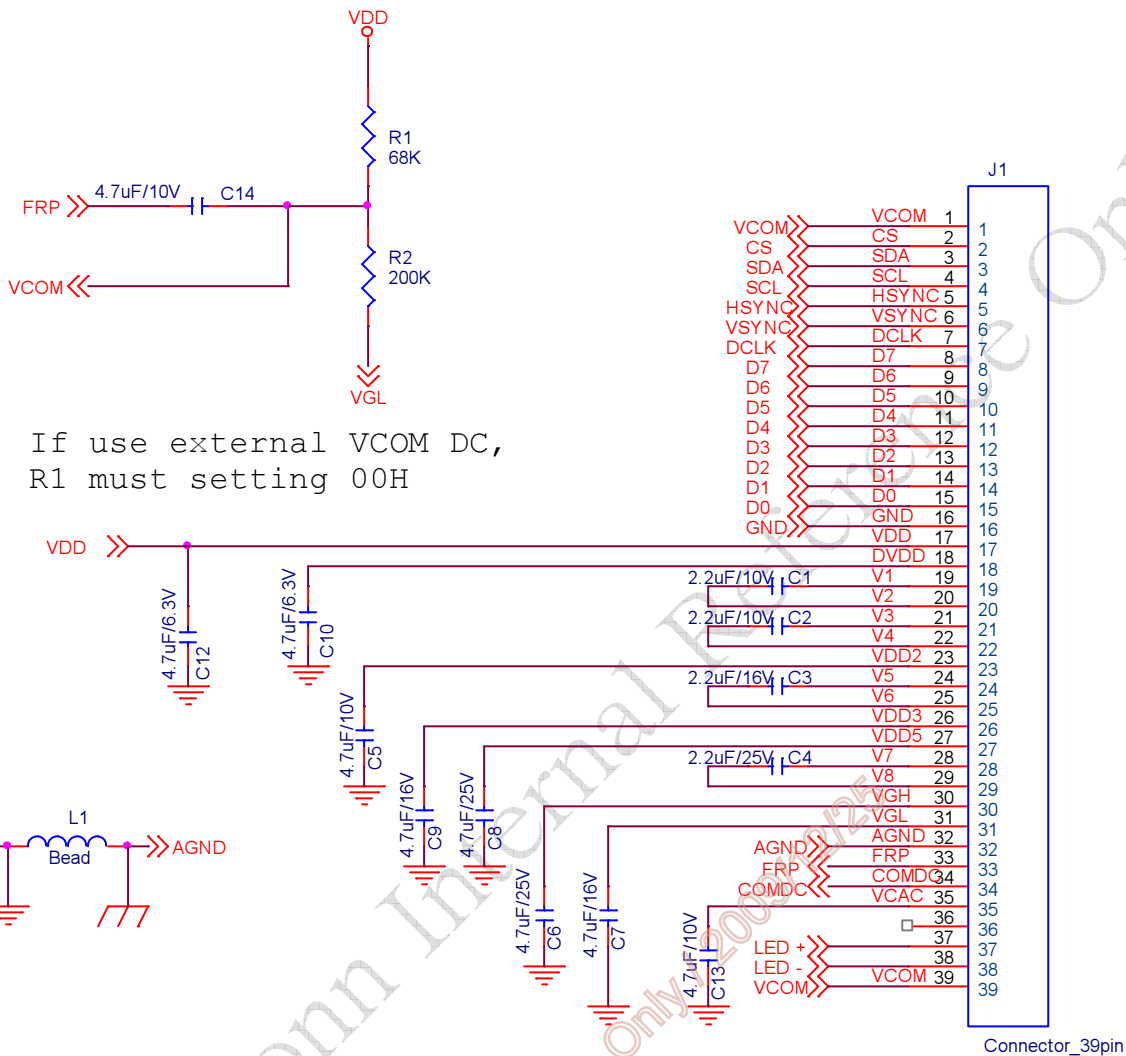

If use external VCOM DC,
R1 must setting 00H

Note1: Use external LED driver must set R5[1](SHDB1)= "0".

Note2: If use external VCOM DC, R1 must setting 00H to disable internal VCOM_DC function.

Note3: **R2 resistor** :

Depending on flick patterns in customer' site, customer can choose a best value to minimize flick issue.

AUO recommends values from 60K to 68K.

2. Power on/off sequence

The register setting of standby mode disabling / enabling is used to control the build-in power on / off sequence.

2.1 Power on (Standby Disabling)

After VDD power on reset, VSYNC/HSYNC/DCLK/DATA can be input, and serial control interface is also operational. The LCD driver is in default standby mode after VDD power-on, and setting register STB to '1' to disable the standby mode is required for normal operation. When the standby mode is disabled, a build-in power on sequence is started. The LCD positive and negative power supplies VGH/VGL are pumped first, and followed by the LED power VLED. Please refer to Fig.10 for the detail timing of power on sequence.

Fig.10 Power on sequence

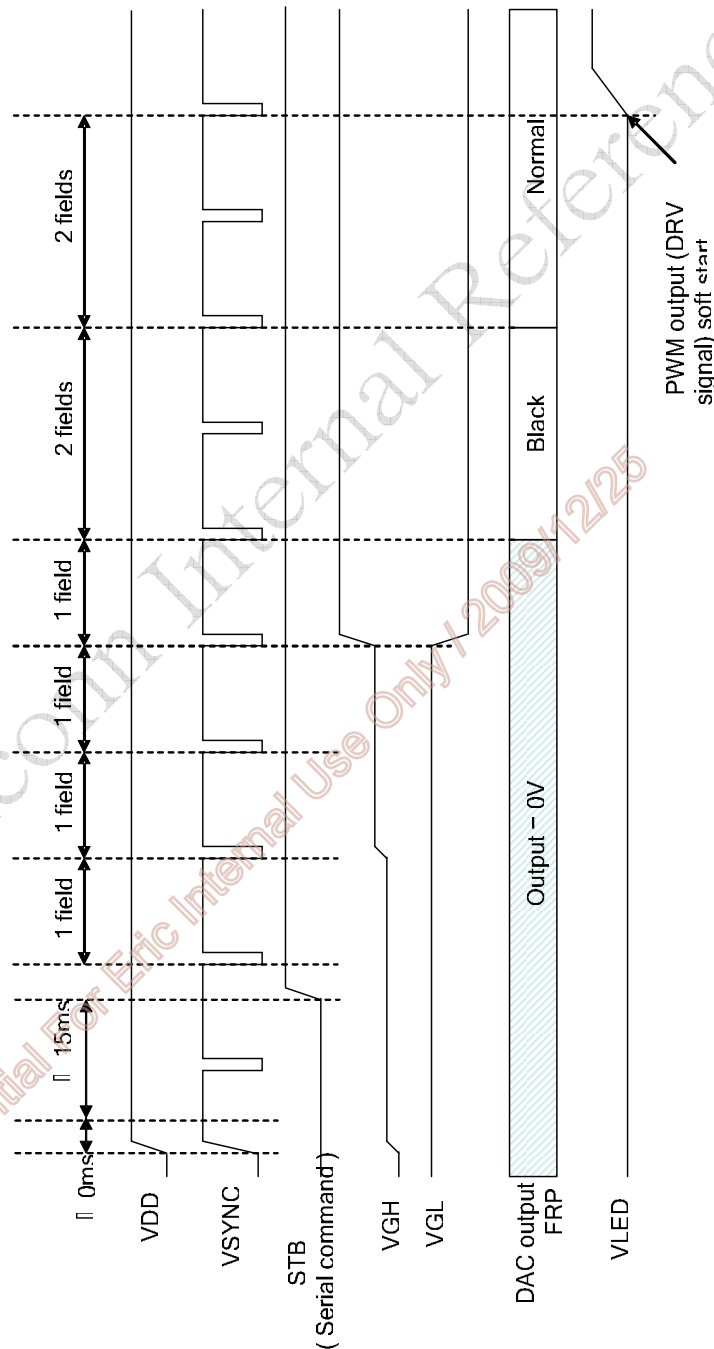

3.2 Power off (Standby Enabling)

When the register STB is set to '0' to enable standby mode, a build-in power off sequence is started. Please refer to Fig.11 for the detail timing of power off sequence.

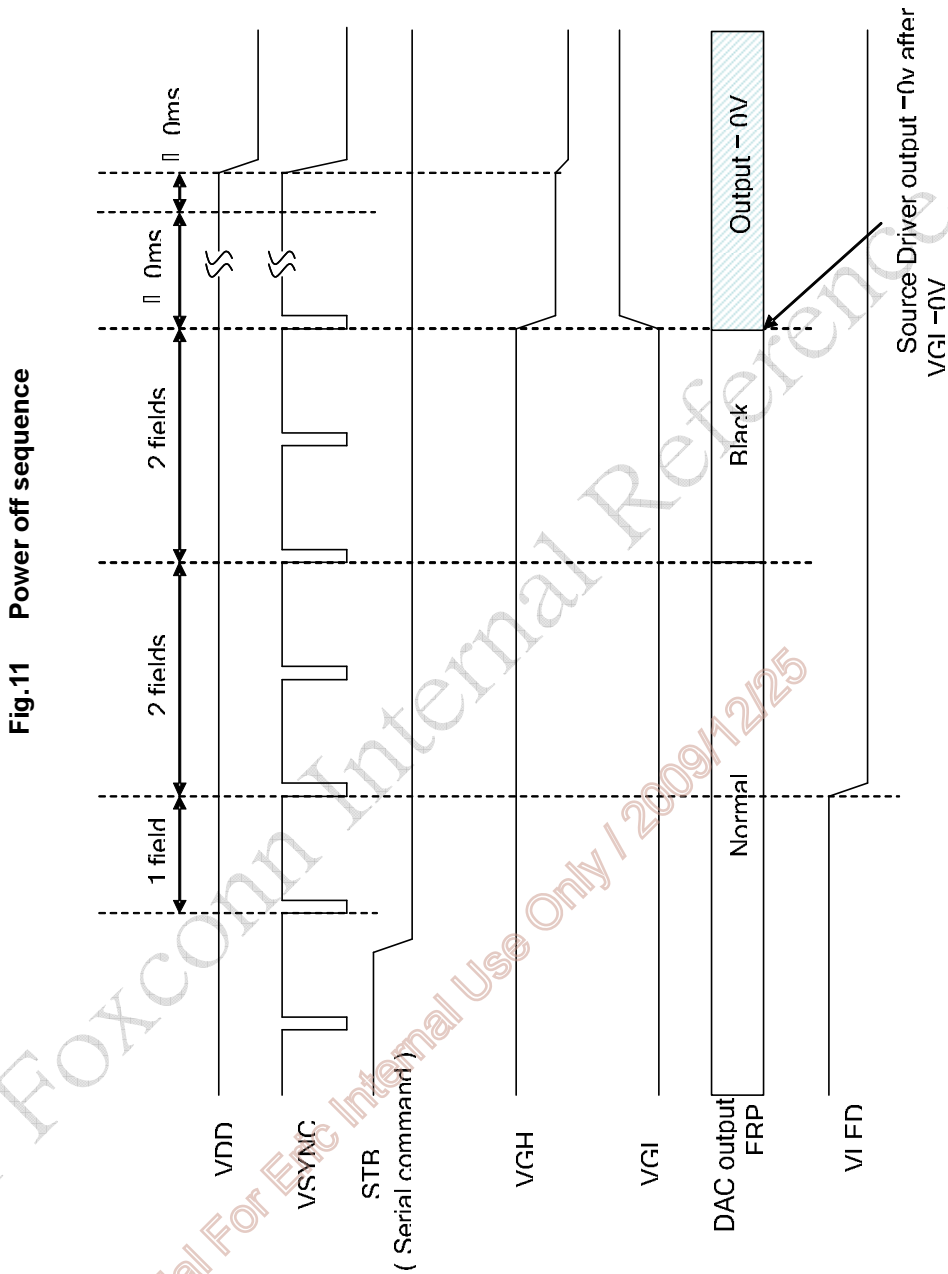

3. Recommended power on/off serial command settings

3.1 UPS051

POWER ON

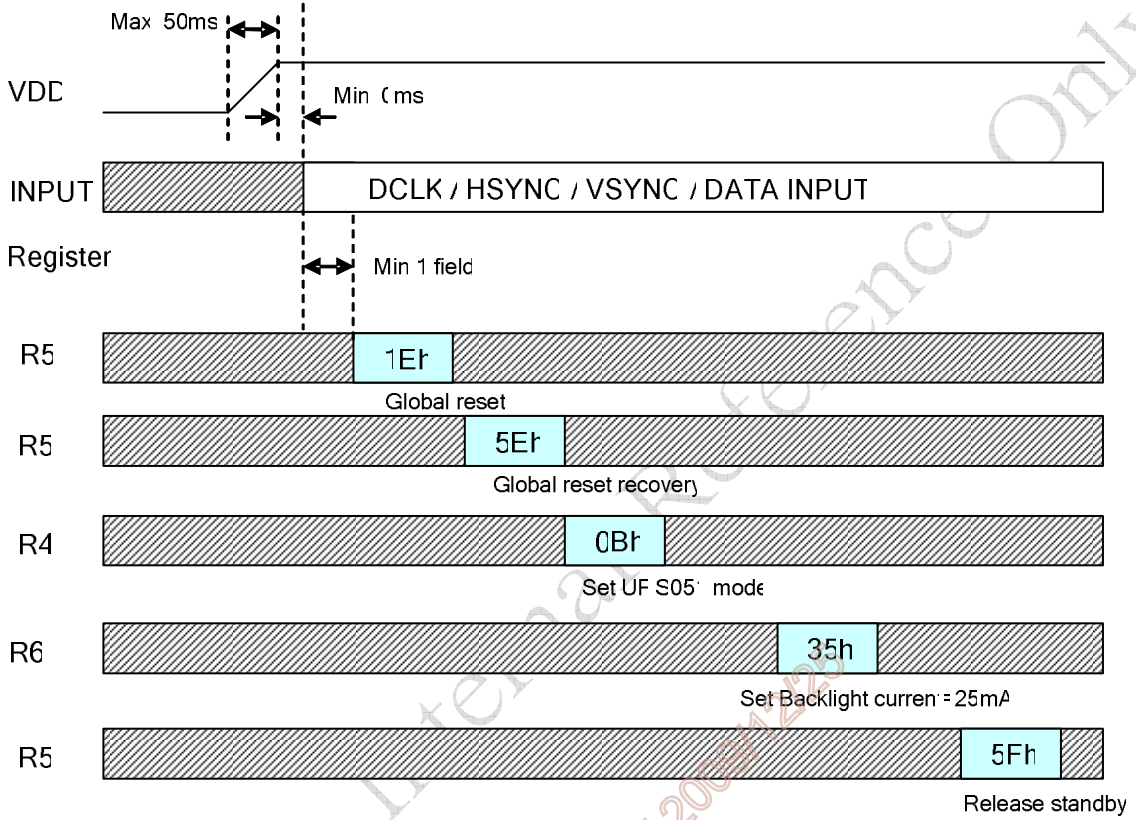

POWER OFF

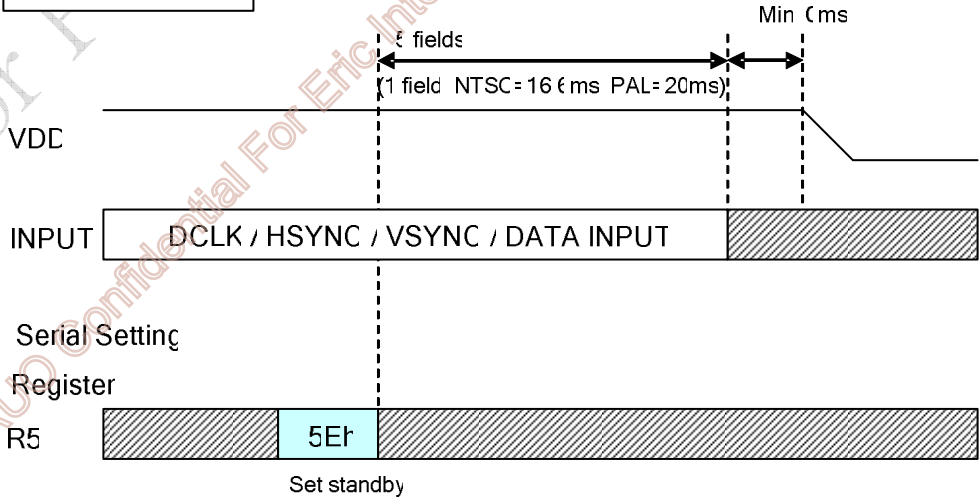



A025DN01 VB Product Spec	Version	0.3
	Page	55/60

3.2 UPS052 320 mode

POWER ON

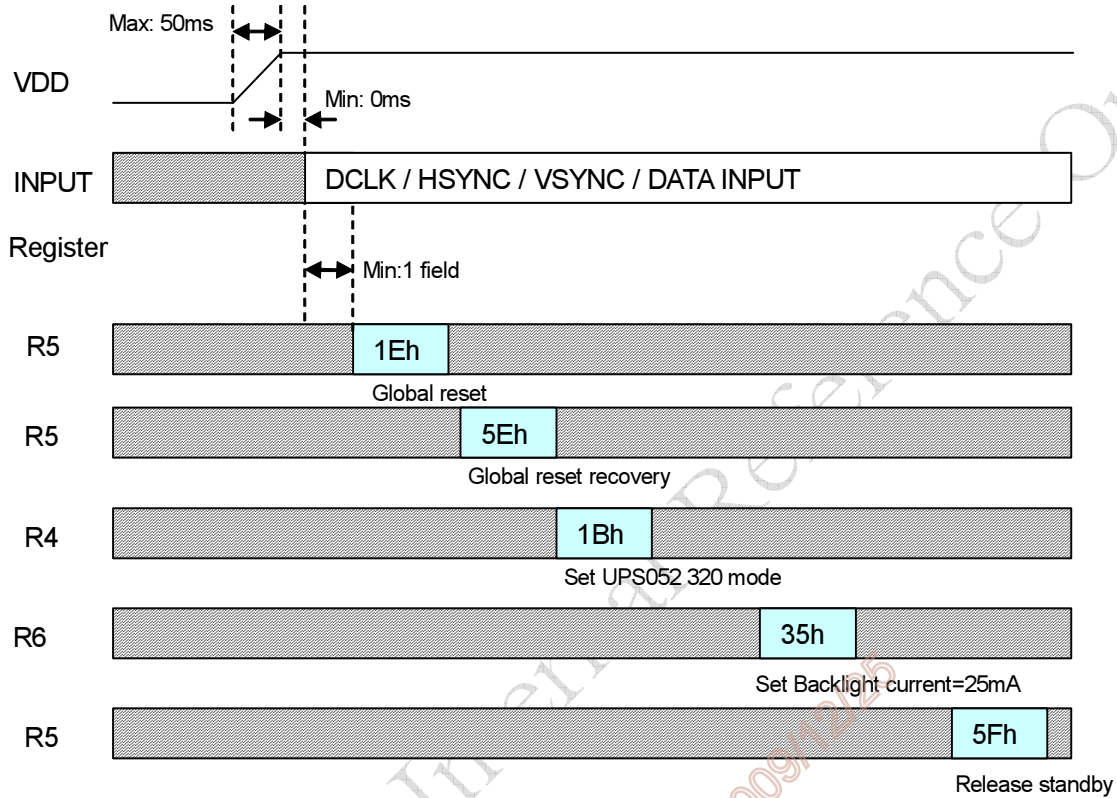

POWER OFF

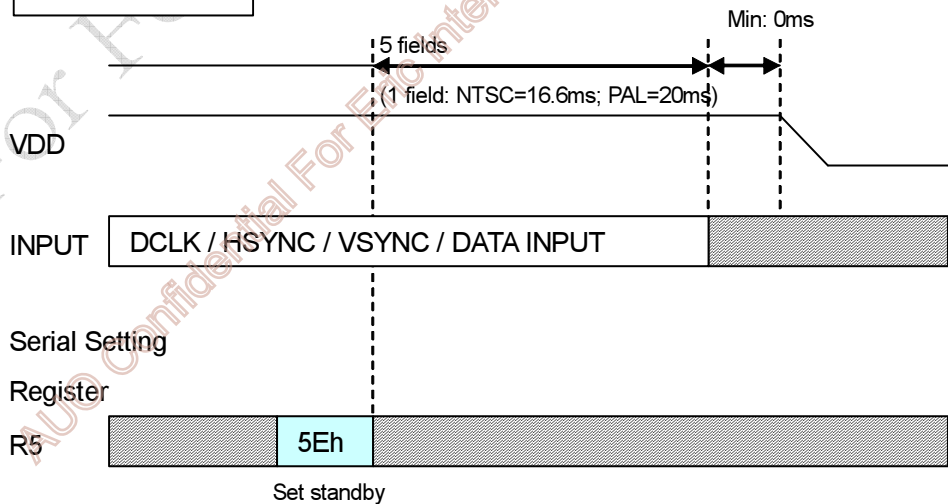



A025DN01 VB Product Spec	Version	0.3
	Page	56/60

3.3 UPS052 360 mode

POWER ON

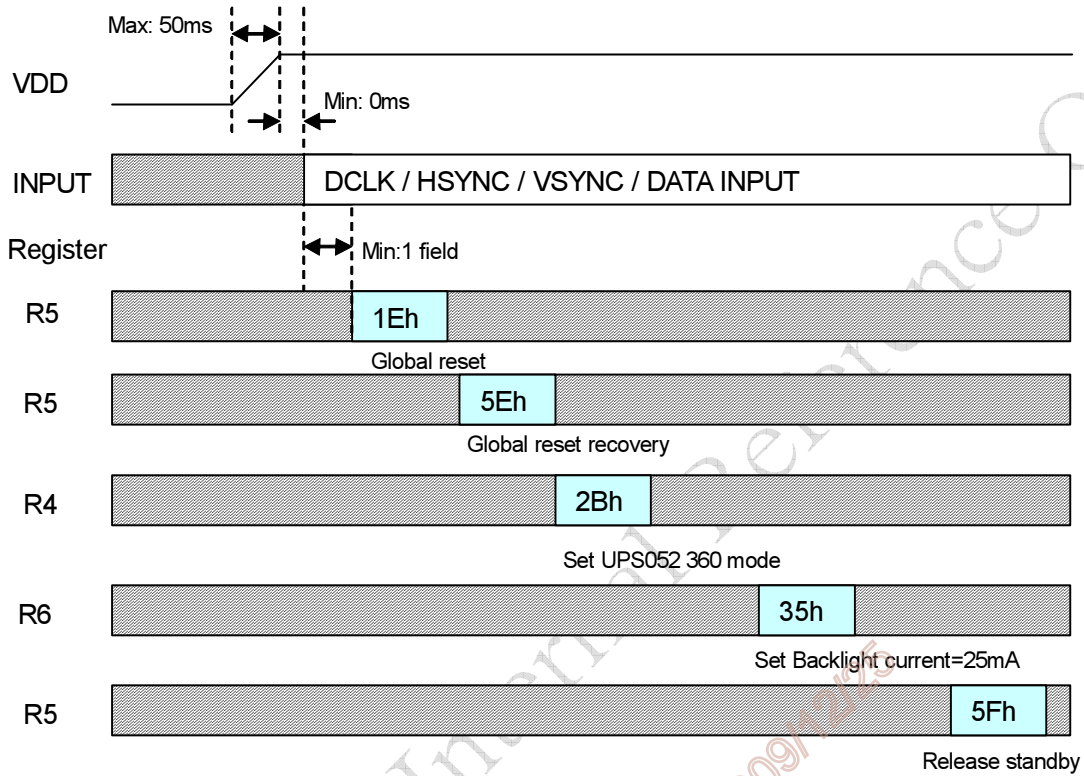

POWER OFF

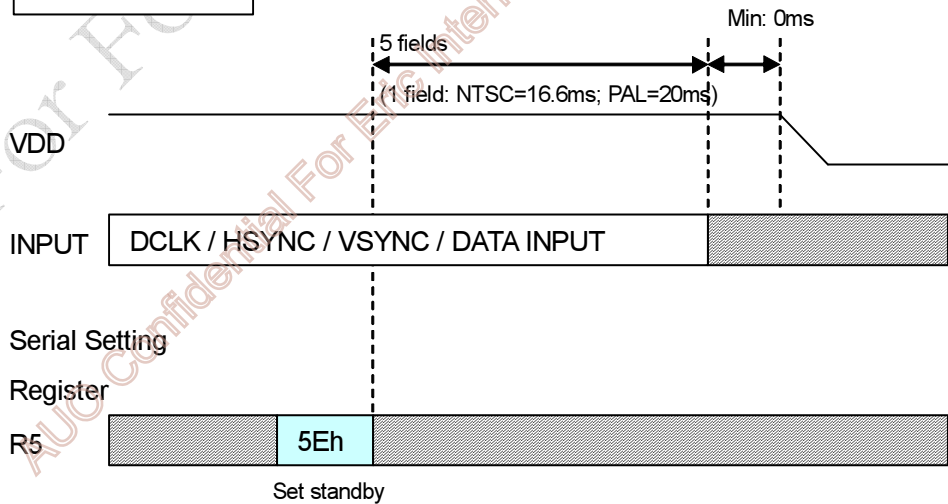



A025DN01 VB Product Spec	Version	0.3
	Page	57/60

3.4 CCIR656

POWER ON

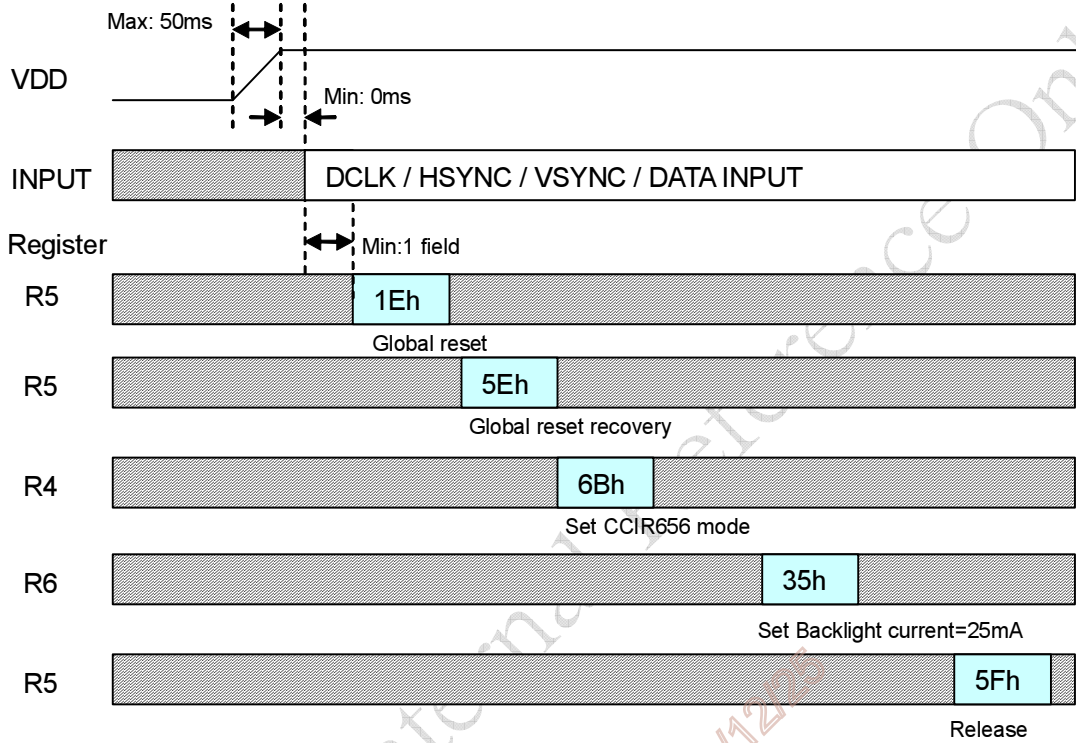

POWER OFF

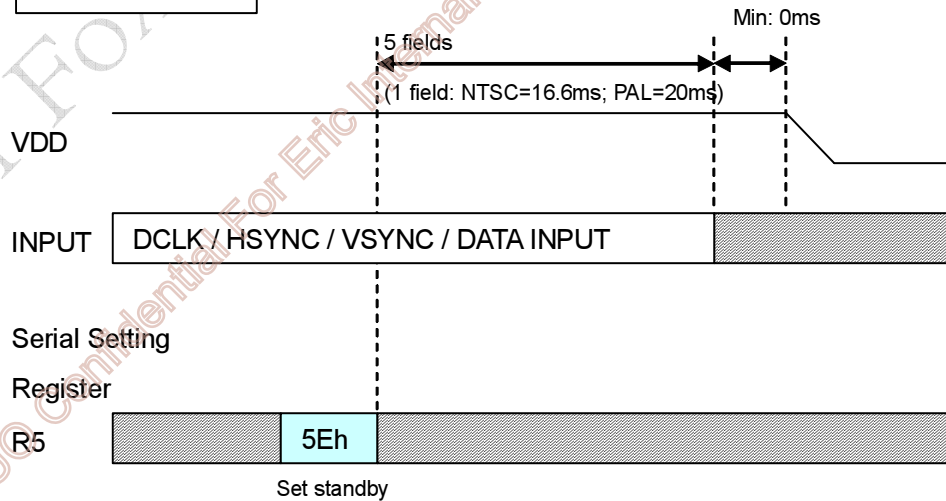



A025DN01 VB Product Spec	Version	0.3
	Page	58/60

3.5 YUV 720

POWER ON

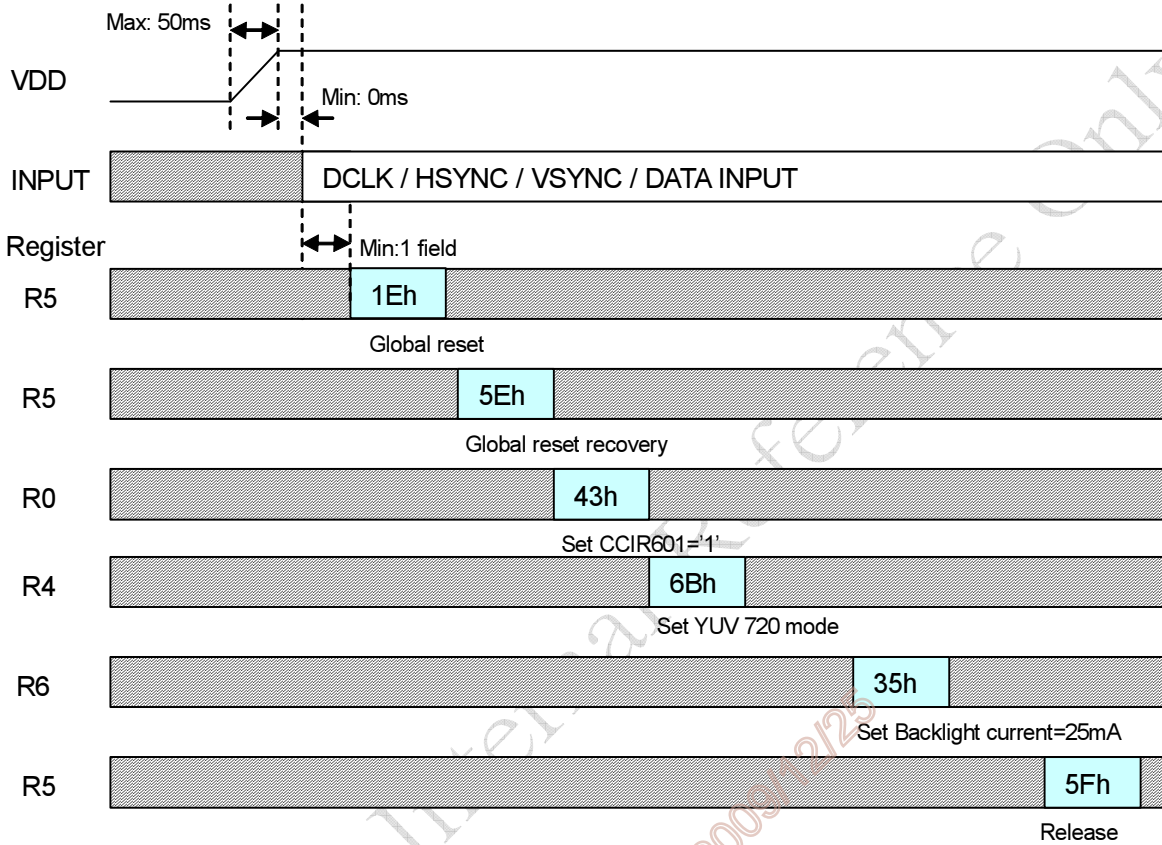

POWER OFF

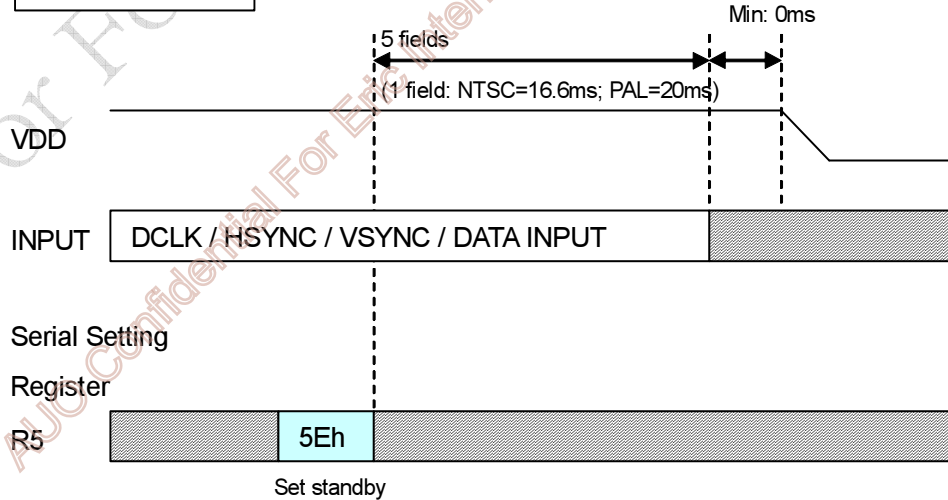



A025DN01 VB Product Spec	Version	0.3
	Page	59/60

3.6 YUV 640

POWER ON

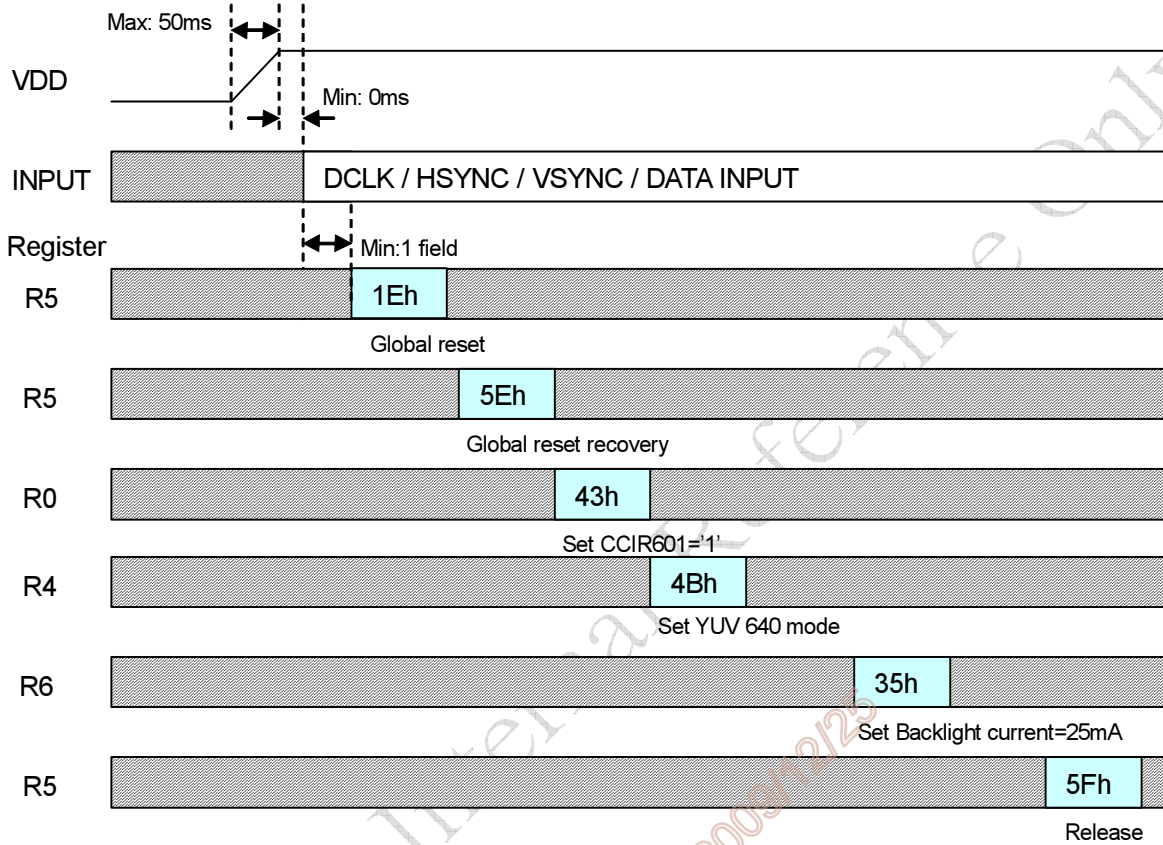

POWER OFF

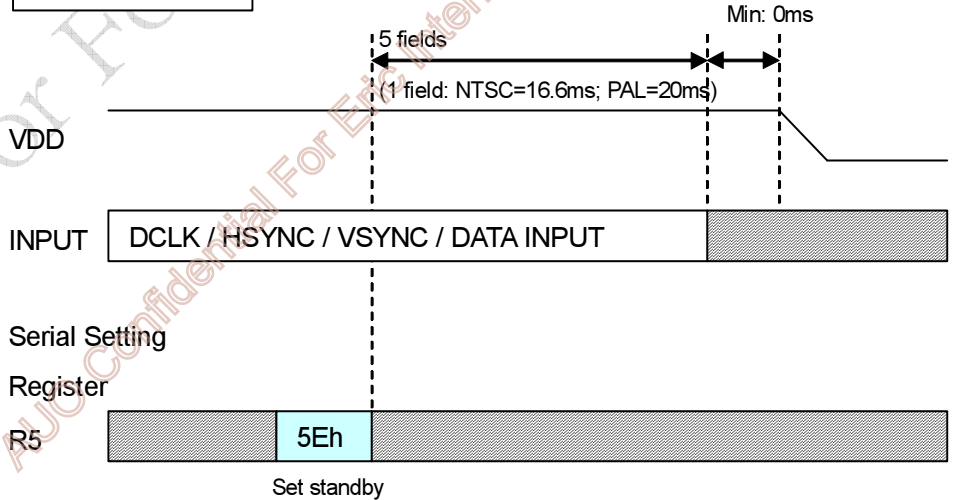

4. Power generation circuit

The block diagram of built-in power generation circuit for TFT-LCD supply power is shown as below:

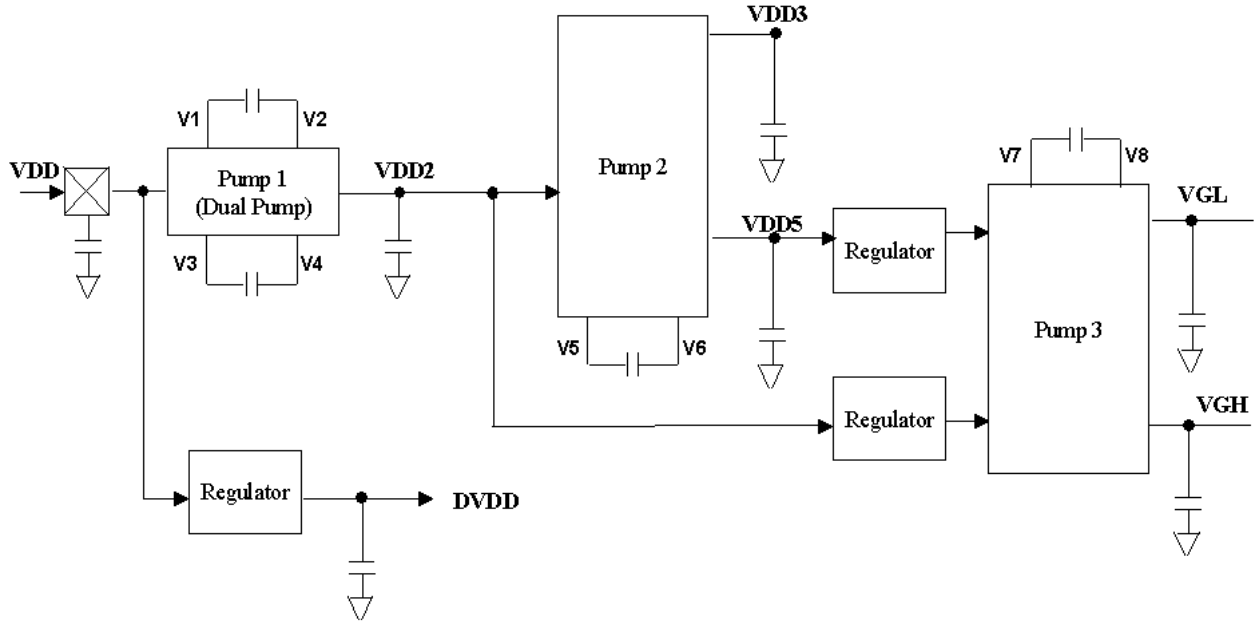

For Foxconn Internal

AUO Confidential For Eric Internal Use Only / 2009/12/25